

**Air Conditioning Control System
Centralized Controller
AE-C400/EW-C50**



**Instruction Book
– Migration Tool –**



Contents

Safety precautions.....	2
1. Introduction.....	4
1-1. About this manual	4
1-2. About the Migration Tool	5
1-3. Operational environment and limitations.....	13
2. PC environment settings	15
2-1. IP address settings.....	15
2-2. Installing .NET Framework.....	16
3. Installation and uninstallation	17
3-1. Installation	17
3-2. Uninstallation.....	20
3-3. Importing the root CA certificate.....	22
4. Procedure of migrating setting data	25
4-1. Preparation.....	26
4-2. Configuration settings for the existing controller and AE-C/EW-C	26
4-3. Monitoring the setting data migrated from the existing controller	28
4-4. Removing the existing controller and installing the AE-C/EW-C	30
4-5. Sending the setting data to the AE-C/EW-C	30
4-6. Editing the setting data of the AE-C/EW-C	31
5. Troubleshooting.....	32
5-1. Log file acquisition method.....	32
6. Trademarks and registered trademarks	33

Before using the controller,
please read this Instruction
Book carefully to ensure proper
operation.
Retain this manual for future
reference.

Safety precautions

- ◆ Thoroughly read the following safety precautions prior to installation.
- ◆ Observe these precautions carefully to ensure safety.

 WARNING	:	indicates a hazardous situation which, if not avoided, could result in death or serious injury.
 CAUTION	:	indicates a hazardous situation which, if not avoided, could result in minor or moderate injury.

- ◆ After reading this manual, pass the manual on to the end user to retain for future reference.
- ◆ The user should keep this manual for future reference and refer to it as necessary. The manual should be made available to those who repair or relocate the product. Make sure that the manual is passed on to any future air conditioning system user.

■ General precautions

WARNING

Do not use the product where large amounts of oil, steam, organic solvents, or corrosive gases (such as ammonia, sulfuric compounds, and acids) are present or where acidic/alkaline solutions or special chemical sprays are used frequently. These substances may corrode the internal parts, resulting in electric shock, performance degradation, malfunction, smoke, or fire.

To reduce the risk of injury, electric shock, or fire, do not alter or modify the product.

To reduce the risk of injury, keep children away while installing, inspecting, or repairing the product.

To reduce the risk of fire or explosion, do not place flammable materials or use flammable sprays around the product.

To reduce the risk of short circuits, current leakage, electric shock, malfunction, smoke, or fire, do not wash the product with water or any other liquid.

To reduce the risk of electric shock, malfunctions, smoke, or fire, do not touch the electrical parts, USB memory device, or touch panel with wet hands.

To reduce the risk of injury or electric shock, before spraying a chemical around the product, stop the operation and cover the product.

If you notice any abnormality (e.g. a burning smell), stop the operation, turn off the product, and contact your dealer. Continuing the use of the product without correcting the abnormality may result in electric shock, malfunction, or fire.

Properly install all required covers to keep dust and moisture out of the product. Dust or moisture entering the product may result in electric shock, smoke, or fire.

! CAUTION

To reduce the risk of injury from broken glass, do not apply excessive force to the glass parts.

To reduce the risk of electric shock or malfunction, do not touch the touch panel, switches, or buttons with a pointed object.

To reduce the risk of injury, electric shock, or malfunction, do not touch sharp edges of parts.

Consult an authorized agency for proper disposal of the product. Inappropriate disposal can lead to environmental pollution.

■ Precautions for relocating or repairing the product**! WARNING**

The product must be relocated or repaired only by qualified personnel. The user must not disassemble or modify the product. Improper installation or repair may result in injury, electric shock, or fire.

1. Introduction

This document contains instructions for operating the Migration Tool for AE-C/EW-C.

1-1. About this manual

[1] Terms used in this manual

- AE-C400 is abbreviated as "AE-C."
- EW-C50 is abbreviated as "EW-C."
- AE-200A/AE-200E/TE-200A is abbreviated as "AE-200."
- AE-50A/AE-50E/TE-50A is abbreviated as "AE-50."
- AG-150A is abbreviated as "AG-150A."
- PAC-YG50ECA is abbreviated as "EC."
- GB-50ADA is abbreviated as "GB-50ADA."
- G-50/G-50-W is abbreviated as "G-50."
- GB-50 is abbreviated as "GB-50."

[2] About screens shown in this manual

The screens shown in this manual are displayed on Microsoft® Windows® 11. Screens other than those of the Migration Tool (for example, installation screen) may appear differently depending on the settings of the PC being used.

1-2. About the Migration Tool

The Migration Tool is designed to reduce workload and setting errors when changing (or updating) old controllers such as G(B)-50/AG-150A/GB-50ADA to the current controllers AE-C/EW-C. The tool extracts setting data from the old controllers and sends them to the AE-C/EW-C to help migrate the setting data including group settings and schedules.

This chapter explains whether setting data can be migrated using this tool for models and functions of old controllers.

For detailed procedures for migrating setting data using this tool, refer to "4. Procedure of migrating setting data."

[1] Target controllers

The table below lists the controllers whose setting data can be migrated to the AE-C/EW-C with this tool.

○: Supported, ✕: Not supported

Old controllers	Migration	Restrictions, etc.
AE-200, EW-50	✕	To be supported in the future
AE-200 + (AE-50/EW-50)	✕	To be supported in the future
AG-150A, GB-50ADA	○	Ver. 3.20 or later ^{*1}
PAC-YG50ECA	○	Ver. 2.20 or later ^{*1 *2 *3 *4}
G-50, G-50-W, GB-50	○	Ver. 3.35 or later ^{*1} Web license needs to be installed.

*1 The AE-C/EW-C is not compatible with transmission models. If a K-transmission model is connected, it must be disconnected in advance.

*2 For transfer from AG-150A (with EC), the following two patterns are selectable.

- Migrating setting data from AG-150A to AE-C (without M-NET), and from EC No. 1 through No. 3 to EW-C No.1 through No. 3
- Merging setting data of AG-150A and EC No. 1 into AE-C, and migrating setting data from EC No. 2 and No. 3 to EW-C No. 2 and No. 3

Refer to "[3] Example 1: Migrating setting data of AG-150A including those of EC."

*3 For AG-150A (with EC), block settings covering multiple ECs are divided and registered with the same block name for each AE-C/EW-C. On the AE-C/EW-C controllers, the block settings registered to block numbers 51 to 150 are converted and migrated to unused block numbers 1 to 50.

Refer to "[3] Example 2: Migrating block settings."

*4 For AG-150A (with EC), the external temperature interlock of the air conditioner with the external temperature sensor (AI controller) covering multiple ECs is deleted.

Refer to "[3] Example 3: Migrating external temperature interlock settings."

[2] Feasibility of migration for each function

The table below shows whether the setting data can be migrated for each function. Some setting data cannot be migrated, such as those not obtainable via LAN communication or those not supported by AE-C/EW-C. Before migration, consider how to handle those data.

The functions listed in the table below include the functions not supported by some models. The setting data of unsupported functions are not migrated.

Feasibility of setting data migration for each function

Function	Availability of function (○: Yes, -: No)		Migration to AE-C/ EW-C ○: Feasible △: Partially feasible ✕: Not feasible
	G-50, GB-50	AG-150A, GB-50ADA	
Unit settings	○	○	△
Network settings (IP address, subnet mask, gateway address)	○	○	✕ ^{*1}
Network settings (extended controller-related settings) → Control target settings (AE-C/EW-C)	-	○ (AG-150A only)	○ ^{*2}
M-NET address	○	○	○ ^{*3}
External input setting	○	○	○ ^{*3}
Group settings	○	○	○
Interlocked LOSSNAY settings	○	○	○
Block settings	○	○	○ ^{*4}
Measurement settings	○	○	○
Measurement alarm e-mail destination setting	○	○	○
Trend data e-mail destination setting	○	○	✕ ^{*1}
Outdoor unit name settings	-	○	○
Floor configuration/name settings (LCD)	-	○	○
Floor layout (LCD)	-	○	○ ^{*3}
Floor layout image	-	○	✕ ^{*1}
HWHP settings	-	○	✕ ^{*5}
Weekly control pattern settings	○	○	○
Schedule - Season settings	-	○	○
Annual control pattern settings	○	○	○ ^{*7}
Annual schedule settings	○	○	○
Energy-saving control settings	○	○	○
System-changeover settings	○	○	○
G-50 LCD schedule settings	○	-	✕ ^{*1}
Error e-mail settings	○	○	○ ^{*3}
Energy-saving peak cut settings (other SC)	○	○	✕ ^{*1}
Energy-saving peak cut settings (electric amount count PLC)	○	○	✕ ^{*1}
Energy-saving peak cut settings (PI controller)	○	○	○

Function	Availability of function (O: Yes, -: No)		Migration to AE-C/ EW-C O: Feasible △: Partially feasible ×: Not feasible
	G-50, GB-50	AG-150A, GB-50ADA	
Energy-saving peak cut settings (external contact input method)	-	○	○ ^{*10}
Energy-saving peak cut settings (demand input PLC method)	○	○	× ^{*1}
Energy-saving peak cut settings (other system method)	○	○	○
Energy-saving peak cut settings (Settings by centralized controller only)	-	-	- ^{*8}
ET control	-	○	○
Advanced power save settings	-	○	○
Thermo-OFF fan settings	-	○	○
Night mode schedule settings	○	○	○
Set temperature range limit	○	○	○
External temperature interlock	-	○	△ ^{*6}
Night setback control	-	○	○
Settings for PLC for general equipment	○	○	×
Interlock control	-	○	○
[Ventilation settings] 24 hr ventilation	-	○	× ^{*9}
[Ventilation settings] Night purge settings	-	○	○
User settings (maintenance, building manager, general user)	○	○	× ^{*1}
Maintenance information transmission, e-mail destination settings	○	○	○
Billing function (TG-2000 billing)	○	○	× ^{*1}
Billing function (AE-C/EW-C billing)	-	-	- ^{*8}
Option license registration	○	○	× ^{*1}
Web browser functions (for administrator and general user)	○	○	× ^{*1}

*1 Setting data are not migrated.

Make settings after migration, if necessary.

The trend data e-mail transmission function is not supported by AE-C/EW-C.

*2 The settings are converted according to the configuration.

See “[3] Example of migrating setting data of AG-150A (with EC).”

*3 Make settings after migration, if necessary.

*4 For migration of the block settings, refer to “[3] Example 3: Migrating external temperature interlock settings.”

*5 The settings of heat pump water heaters cannot be migrated from AG-150A to AE-C because connectable models differ between AG-150A and AE-C.

*6 For AG-150A (with EC), settings of the AI controller that covers multiple ECs and is selected as an outdoor temperature measurement unit are not migrated. Refer to “[3] Example 2: Migrating block settings.”

*7 For the annual schedule control pattern, the G-50 setback settings are not migrated.

*8 This is a new function of AE-C/EW-C. Make settings for this function after setting data migration.

1. Introduction

- *8 This is a new function of AE-C/EW-C. Make settings for this function after setting data migration.
- *9 Since the settings are stored in the ventilation equipment, they will not be migrated if the ventilation equipment is replaced together with the controller. Make settings after setting data migration, if necessary.
- *10 For migration of peak cut settings of the PI controller connected to the AG-150A (with EC) via an EC, the migration destination AE-C/EW-C to which a PI controller is connected is referred to as a remote SC (peak cut method selection) by an AE-C/EW-C to which no PI controller is connected.

[3] Example of migrating setting data of AG-150A (with EC)

When migrating setting data from AG-150A (with EC), the setting data of EC are basically migrated to EW-C. However, by merging AG-150A with EC without designating any controller as a migration destination, the first controller can be an AE-C.

In this case, AG-150A is merged with EC1 for migration.

Example 1: Migrating setting data of AG-150A including those of EC

Shown below is an example of migration of group settings.

- When AG-150A (with EC) is merged with EC1:
Model relation

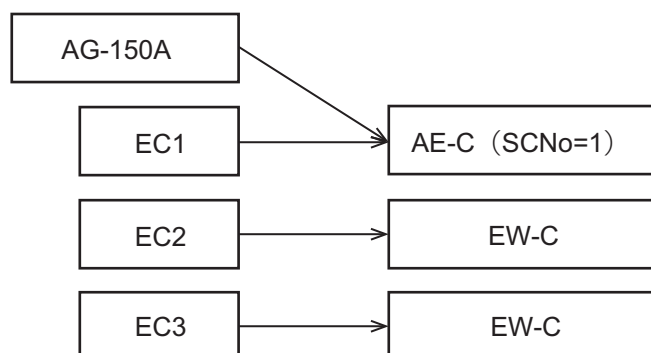

- When AG-150A (with EC) is not merged with EC1:
Model relation

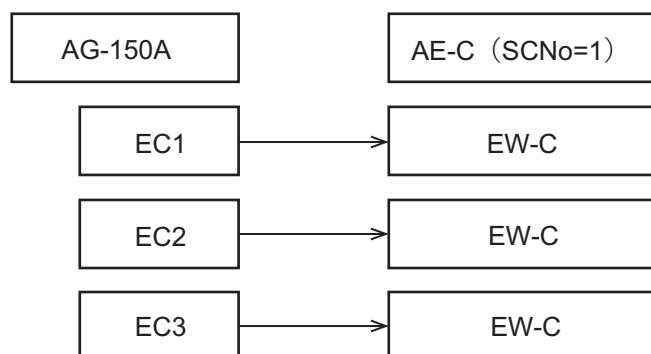

Since the group settings are retained by the EC connected to M-NET, they are migrated as shown above. However, the mail communication function settings, which are retained by AG-150A, are migrated to the destination AE-C (SCNo=1) as shown below.

- When AG-150A (with EC) is merged with EC1:
Model relation

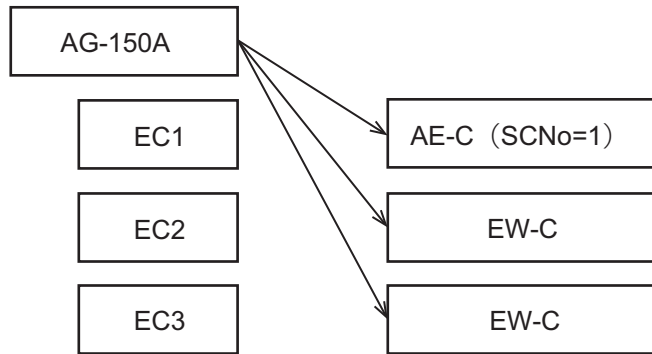

- When AG-150A (with EC) is not merged with EC1:
Model relation

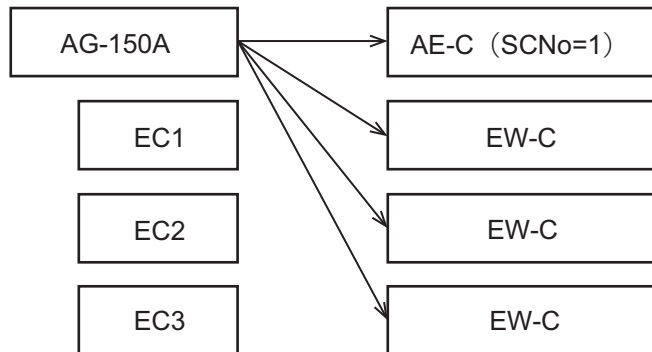

Example 2: Migrating block settings

- Before migration

AG1 (G50No=1)		Group		
Block no.	Block name	EC1	EC2	EC3
1	block 1	1, 2, 3	1, 2, 3	1, 2, 3
2	block 2	4, 5, 6	4, 5, 6	4, 5, 6
3	block 3	7, 8, 9	7, 8, 9	7, 8, 9
51	block 51	10, 11	10, 11	10, 11
150	block 150	49, 50	49, 50	49, 50

- After migration

EW-C1 (ScNo=1)		Group	Remarks
Block no.	Block name		
1	block 1	1, 2, 3	
2	block 2	4, 5, 6	
3	block 3	7, 8, 9	
4	block 4	10, 11	Original block no. : 51
5	block 5	49, 50	Original block no. : 150

EW-C2 (ScNo=2)		Group	Remarks
Block no.	Block name		
1	block 1	1, 2, 3	
2	block 2	4, 5, 6	
3	block 3	7, 8, 9	
4	block 4	10, 11	Original block no. : 51
5	block 5	49, 50	Original block no. : 150

EW-C3 (ScNo=3)		Group	Remarks
Block no.	Block name		
1	block 1	1, 2, 3	
2	block 2	4, 5, 6	
3	block 3	7, 8, 9	
4	block 4	10, 11	Original block no. : 51
5	block 5	49, 50	Original block no. : 150

Example 3: Migrating external temperature interlock settings

- Before migration

AG-150A	Group		Setting
External temperature sensor	EC no.	Group	
1-49-1	1	1	None
		2	+1
		3	+2
		49	+3
		50	+4
	2	1	None
		2	+1
		3	+2
		49	+3
		50	+4
	3	1	None
		2	+1
		3	+2
		49	+3
		50	+4

- After migration

AE-C	External temperature sensor	Group	Setting
ScNo			
1	49-1	1	None
		2	+1
		3	+2
		49	+3
		50	+4
2	Unset	1	None
		2	+1
		3	+2
		49	+3
		50	+4
3	Unset	1	None
		2	+1
		3	+2
		49	+3
		50	+4

1-3. Operational environment and limitations

Shown below is available combinations of versions of AE-C/EW-C and related tools, PC operating environment, and other limitations for use of the Migration Tool.

Version combination constraints

Migration Tool

AE-C/EW-C version	Software version
Ver. 1.00 to 1.25	Unavailable
Ver. 1.30 and later	Ver.1.00

[1] PC environment

Shown below is the PC operating environment for using the Migration Tool and other tools.
 Connect the tools to the same network as AE-C/EW-C.

PC operating environment

○: Applicable

Item	Requirements	(3) Migration Tool			Remarks
		(2) Initial Setting Tool			
		(1) Browser			
CPU	1.0 GHz or more	○	○	○	
RAM	4 GB or more	○	○	○	
Image resolution	1024 x 768 or more	○	○	○	
Supported OS	Microsoft Windows 11 (64bit)	○	○	○	
	MacOS®	○			
Operating environment	.NET Framework 4.8 or higher		○	○	
	Microsoft Excel 2021 32bit		○	○	
Supported browser	Microsoft Edge	○			
	Google Chrome	○			
	Safari	○			
USB	1 port or more		○		Used for importing and exporting data
LAN port	100Base-TX or higher	○	○	○	

2. PC environment settings

This section describes the PC environment settings for use of the Migration Tool.

2-1. IP address settings

Set the IP address of the PC for use with the Migration Tool. The IP address of the PC must not overlap with that of the centralized controller, and must be set to an IP address with the same network address.

For example, if the IP address of LAN1 on the centralized controller is the default value (192.168.1.1) and the subnet mask is also the default value (255.255.255.0), set the IP address of the PC for use with the Migration Tool to 192.168.1.101. In the above example, 192.168.1 is the network address.

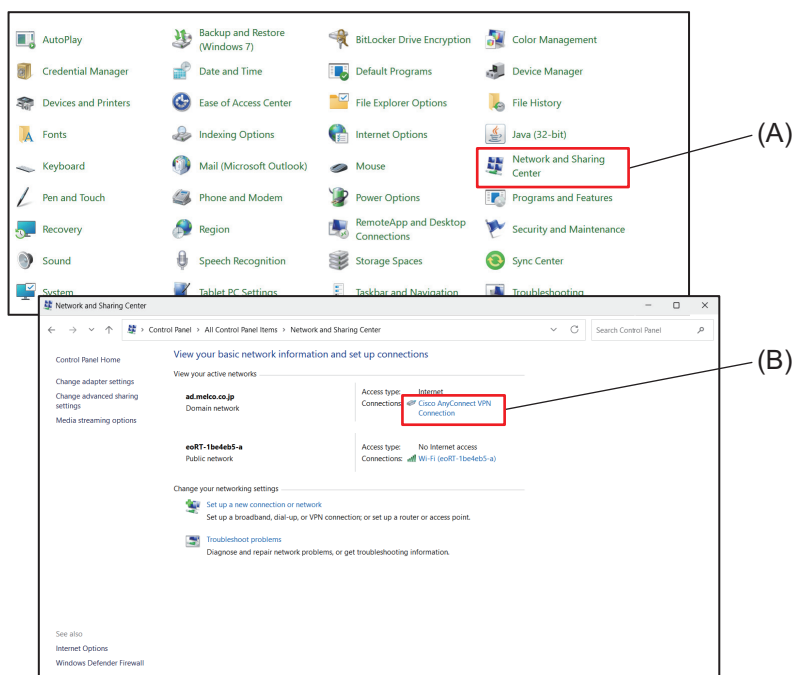

Step

1. Search for [Control Panel] using the search box on the PC, and open the Control Panel.
2. Click [**Network and Sharing Center**] (A), and the Network and Sharing Center window will appear.
3. Click [**Ethernet**] (B). This link may appear as [**Ethernet 1**] or [**Local Area Connection**].

2. PC environment settings

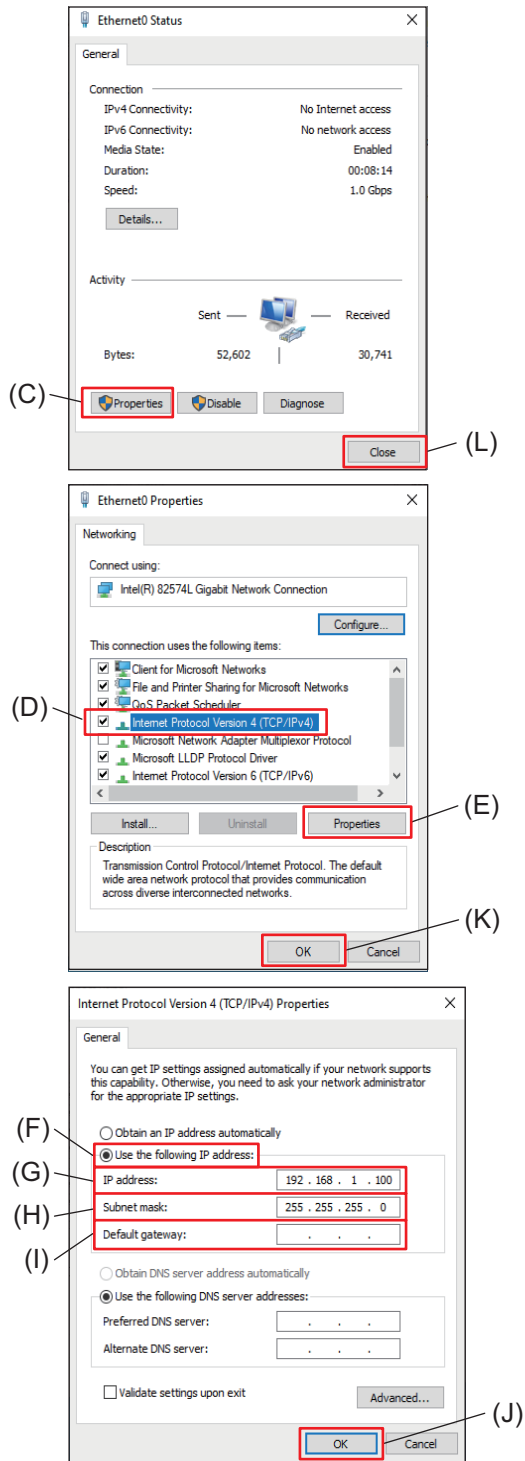

4. Click (C).
5. Select [Internet Protocol 4 (TCP/IPv4)] (D), and click (E).
6. Select (F).
7. Enter the IP address of the PC in (G).
ex.) 192.168.1.101
8. Enter the subnet mask in (H).
ex.) 255.255.255.0
9. Enter the gateway address in (I) if necessary.
10. Click (J), (K), and (L), and close the window.
11. Close the Control Panel.

- Request your system administrator to provide the IP address (G), subnet mask (H), and gateway address (I).

2-2. Installing .NET Framework

If the version of .NET Framework is earlier than 4.8, download the .NET Framework 4.8 installer from the following URL and install it.

<https://go.microsoft.com/fwlink/?LinkId=2085155>

3. Installation and uninstallation

This section explains how to install and uninstall the Migration Tool.

At each step during the installation, clicking [Cancel] will abort the installation or uninstallation. To return to the previous screen, click [Back].

3-1. Installation

Step

1. Double-click the installer of the Migration Tool (setupMigrationToolAECE_VXXX.msi). The setup program will start.
VXXX : Version of the tool (For example, version 3.00 is indicated as V300.)
2. Check the information displayed on the startup screen of the Migration Tool setup program, and if you agree, click [Next].

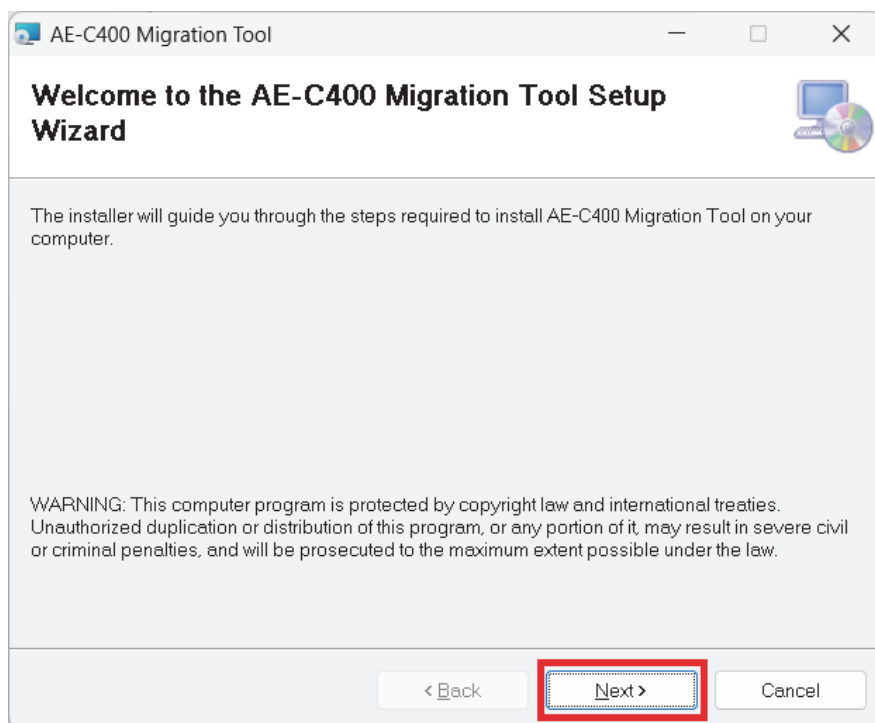

3. Installation and uninstallation

3. Check the folder to install the program, and click [Next].

To change the installation location, click [Browse] to select the installation folder.

The default settings for the installation location folder are as follows.

Tool name	Installation location
Migration Tool	C:\Program Files (x86)\MITSUBISHI ELECTRIC CORPORATION\AE-C400 Migration Tool\

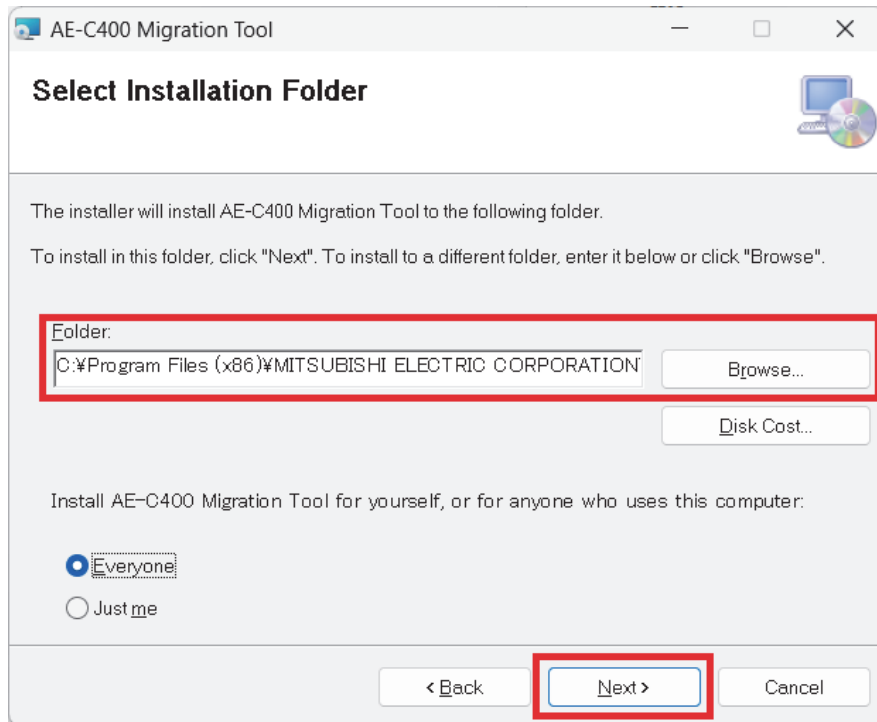

4. To start the installation, click [Next].

To cancel the installation, click [Cancel].

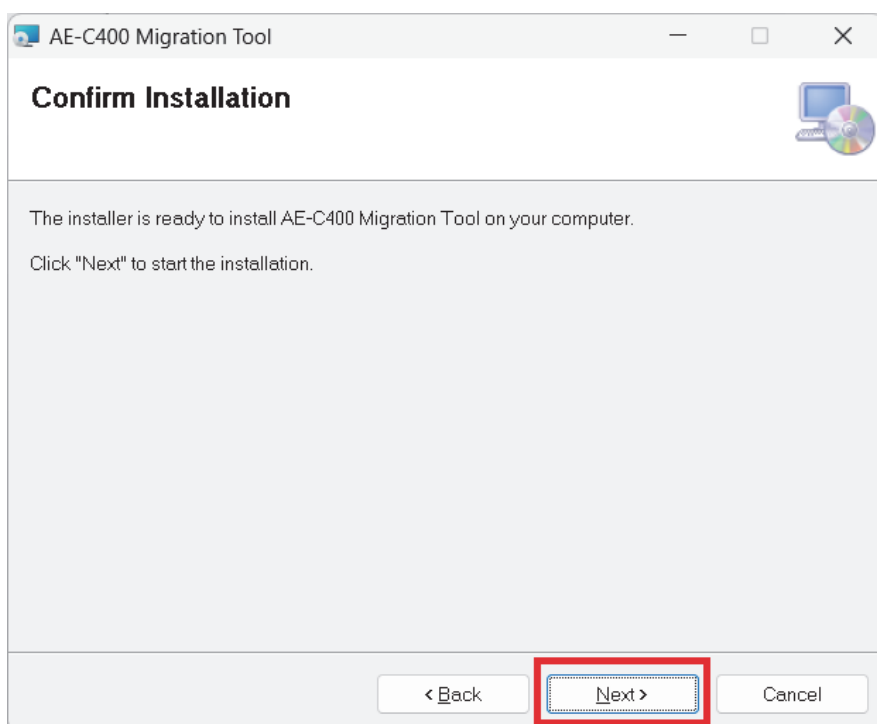

5. Click [Close] on the installation completion screen.
Check that the [AE-C400 Migration Tool] shortcut is in the AE-C400 folder of the start menu.

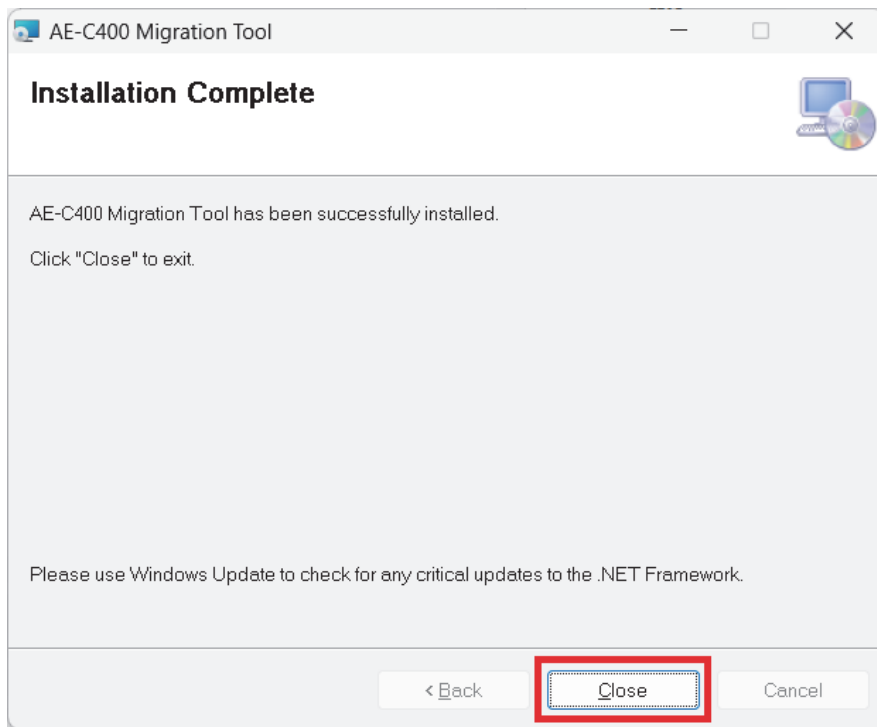

6. Click [AE-C400 Migration Tool CACertificateImporter] in the tool menu of the Windows Start menu.
* A black window screen appears momentarily, and the import of the root certificate completes.

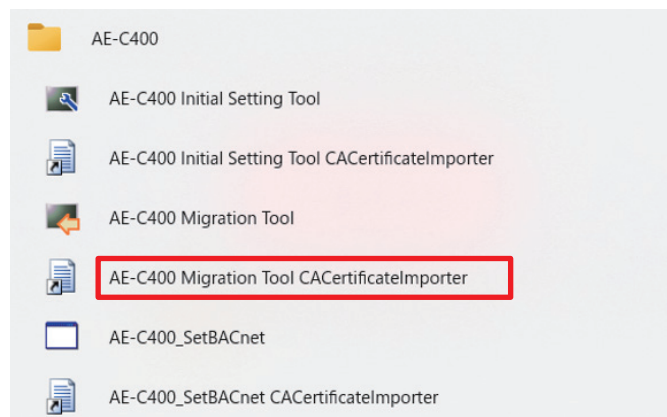

3-2. Uninstallation

This section explains how to uninstall the Migration Tool.
Normally, it is not necessary to uninstall the program.

Step

1. Ensure that the Migration Tool has been exited.
If not, exit it.
2. Click [Control Panel] on the Start menu to open the Control Panel.
3. Select [Programs and Features] on the Control Panel screen to display the Programs and Features screen.

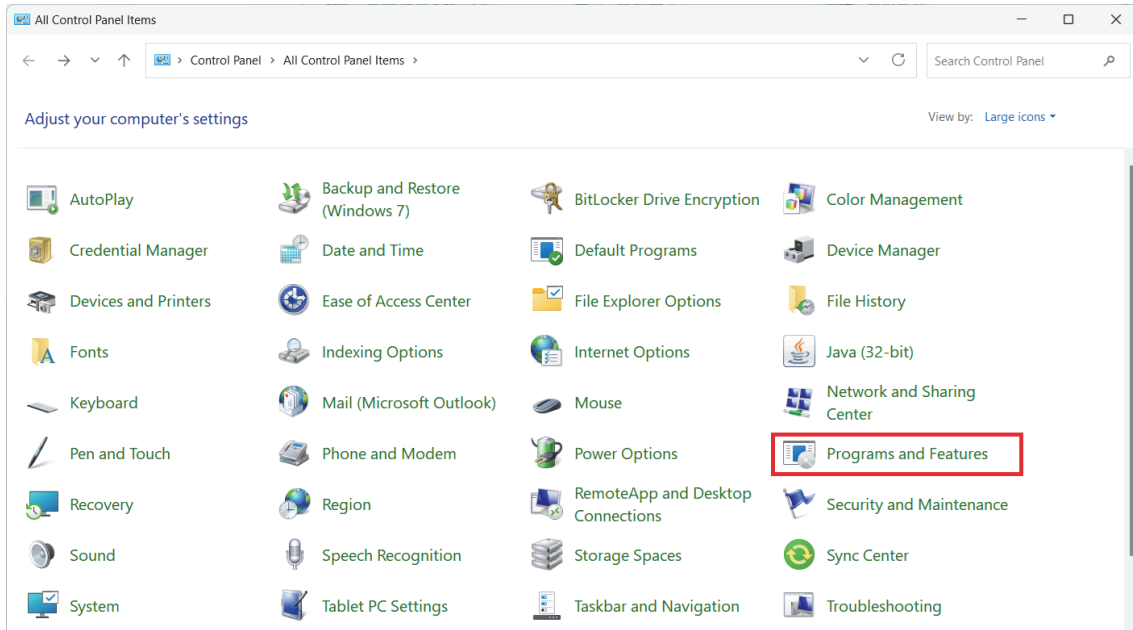

4. On the Programs and Features screen, click [AE-C400 Migration Tool].
Alternatively, click [AE-C Migration Tool], and then right-click and select [Uninstall].
The program will be uninstalled.

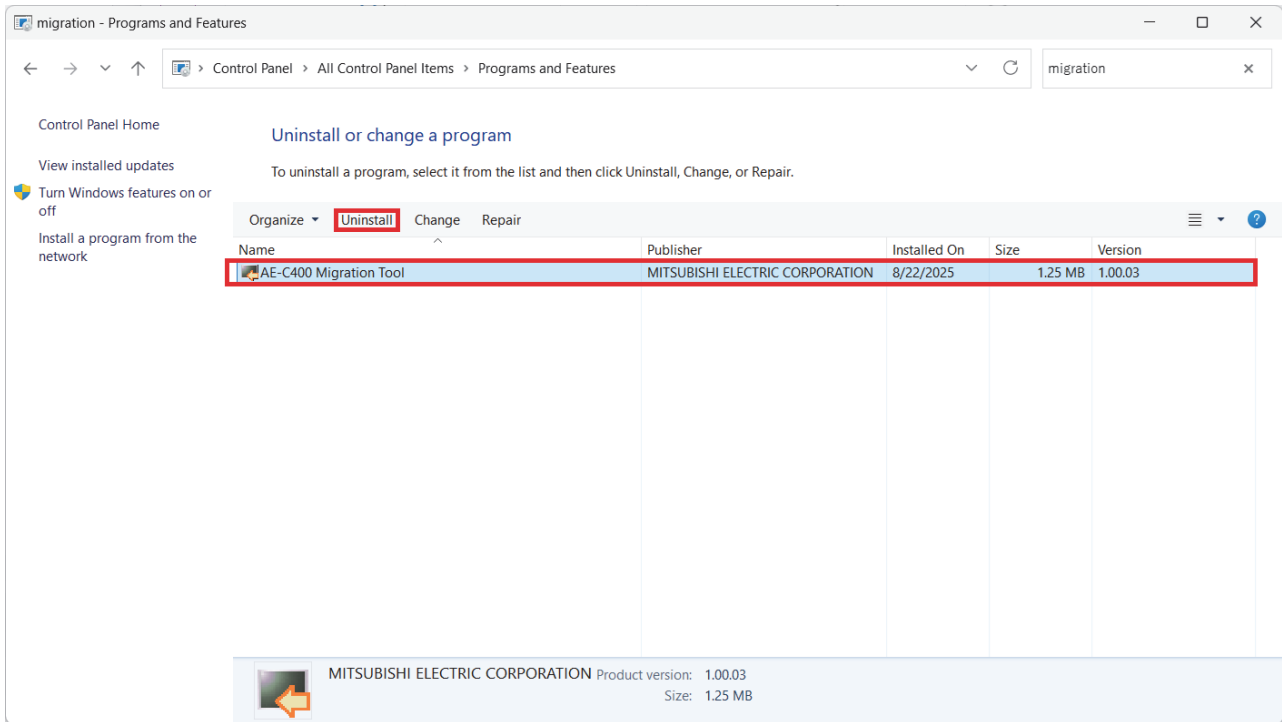

The uninstallation of the Migration Tool is complete here.

3-3. Importing the root CA certificate

[1] Importing using the installed tools

Check that the AE-C400 Migration Tool is already installed.

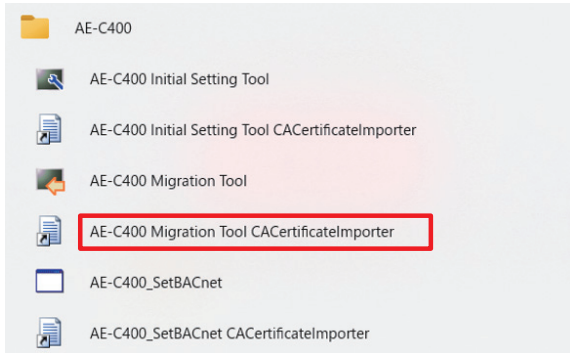

Click [AE-C400 Migration Tool CA Certificate Importer] in the menu of each tool on the Windows Start menu.

[2] Importing the certificate via browser

The AE-C/EW-C controller encrypts communication data using HTTPS (SSL).

Therefore, it is necessary to configure the following settings to monitor and control the operation status via an encrypted Web page.

Register the AE-C/EW-C certificate managed by the browser to the PC to be used.

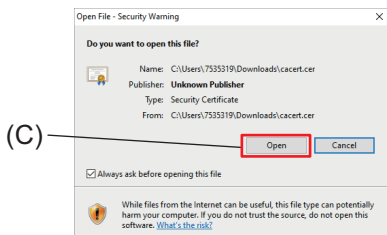
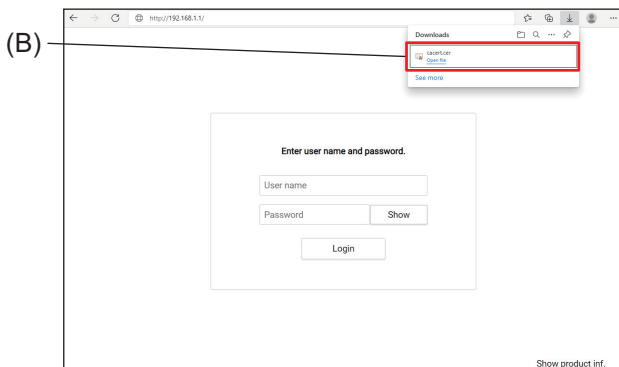
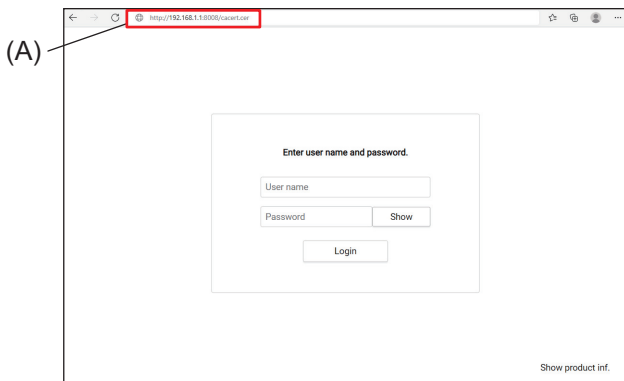

Step

1. Enter the following Web page address in the address bar (A), and click [Enter].
http://(IP address of AE-C or EW-C):8008/cacert.cer
ex.) http://192.168.1.1:8008/cacert.cer
 - Although the AE-C/EW-C controller integrates multiple AE-C/EW-C controllers to monitor and operate air conditioning units, the certificate can be registered from any one of the controllers to the PC.
2. Click (B) on the taskbar.
 - Depending on the browser used, downloaded files may not be displayed on the taskbar. If they are not displayed, run cacert.cer in the installation folder.
3. Click (C).

4. Click (D).

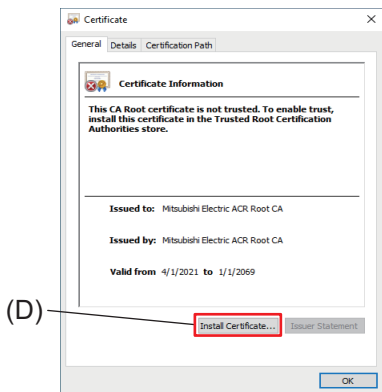

5. Click (E).

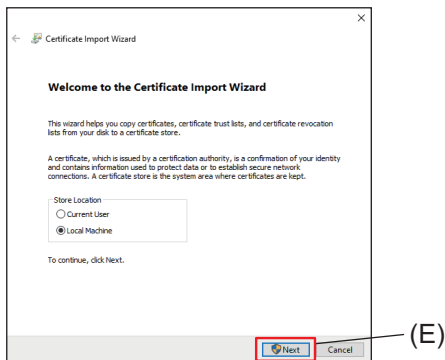

6. Select (F), and click (G) to open (a).

7. Select (H), and click (I) to close (a).

8. Click (J).

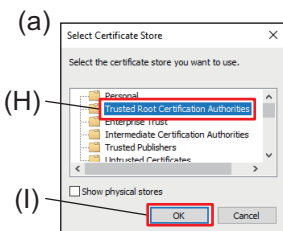
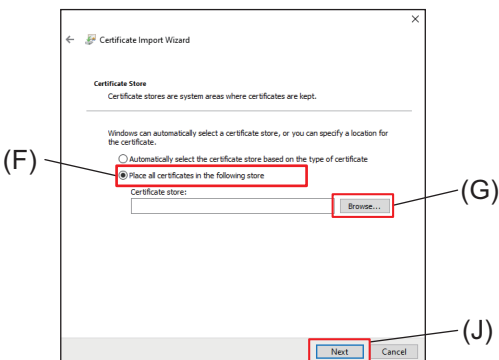

9. Click (K).

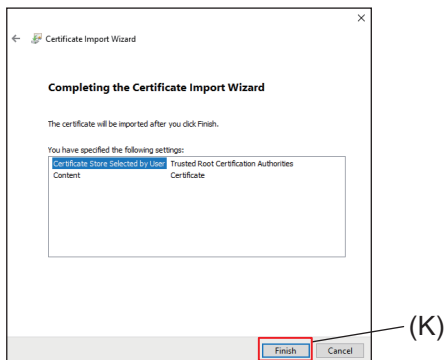

3. Installation and uninstallation

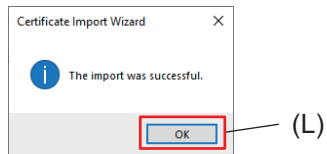

10. Click (L).

11. Log in by entering the following Web page address in the address bar of the Web browser.
[https://\(IP address of AE-C/EW-C to be logged in\)/control/](https://(IP address of AE-C/EW-C to be logged in)/control/)

- Use the Initial Setting Tool to configure the AE-C/EW-C to be logged in.
- Successful login means that the certificate has been installed correctly.

4. Procedure of migrating setting data

This chapter describes the procedure of migrating the setting data of an existing controller to AE-C/EW-C using the Migration Tool.

The following is an overview of the migration process using this tool.

To obtain the setting data from the migration source controller, the ID and password of the commissioning user/building manager of the source controller is required. To send the setting data to the migration destination controller, the ID and password of the commissioning user/building manager of the destination controller is required. Prepare those IDs and passwords before starting migration.

Step	Item	Task	Reference
(1)	Existing controller	Preparation (update to the latest S/W, etc.)	4-1.
(2)	Migration Tool	Configuration setting for the existing controller and AE-C/EW-C	4-2.
(3)	Migration Tool	Loading the setting data from the existing controller	4-3.
(4)	Existing controller	Removal of the existing controller	4-4.
(5)	AE-C/EW-C	Installation of the AE-C/EW-C	
(6)	Migration Tool	Converting and sending the setting data to the AE-C/EW-C	4-5.
(7)	Initial Setting Tool	Edit and reconfiguration (if necessary)	4-6.

(1) Advance preparation (S/W version update)

(4) Removing existing controller

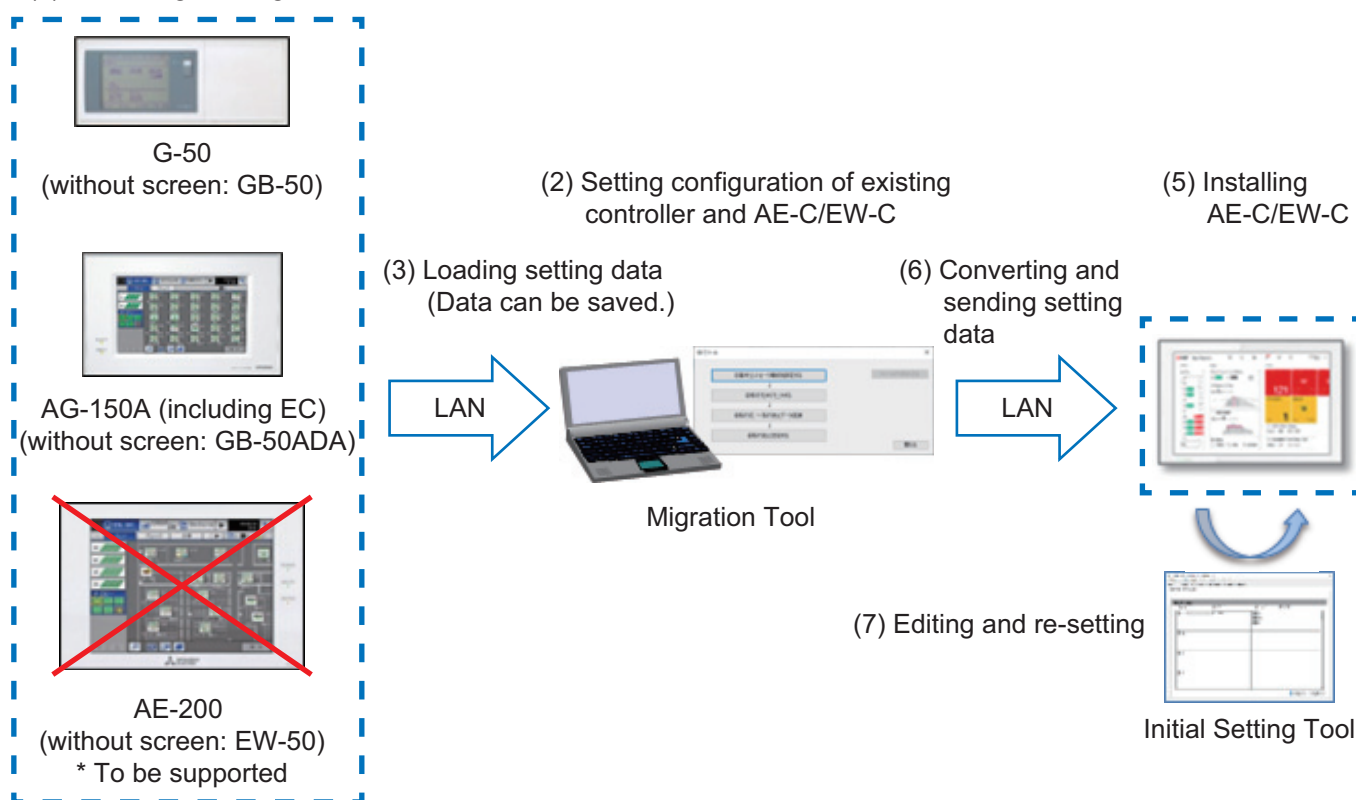

4-1. Preparation

Perform the following steps for preparation.

Step

1. If the software version of the data source controller is earlier than the version shown in the table below, update the software.
For the procedure of updating the software, refer to the instruction manual for the data source controller.

Existing controller	Software version
AG-150A, GB-50ADA	Ver. 3.20 or later
PAC-YG50ECA	Ver. 2.20 or later
G-50, G-50-W, GB-50	Ver. 3.35 or later Web license must be installed.

2. For G-50/GB-50, install a Web license.
3. If a K-control model is connected, delete its registration from the centralized controller.

4-2. Configuration settings for the existing controller and AE-C/EW-C

Set the configuration of the centralized controller according to the steps below.

Step

1. Start the [AE-C400 Migration Tool] from the Start menu.

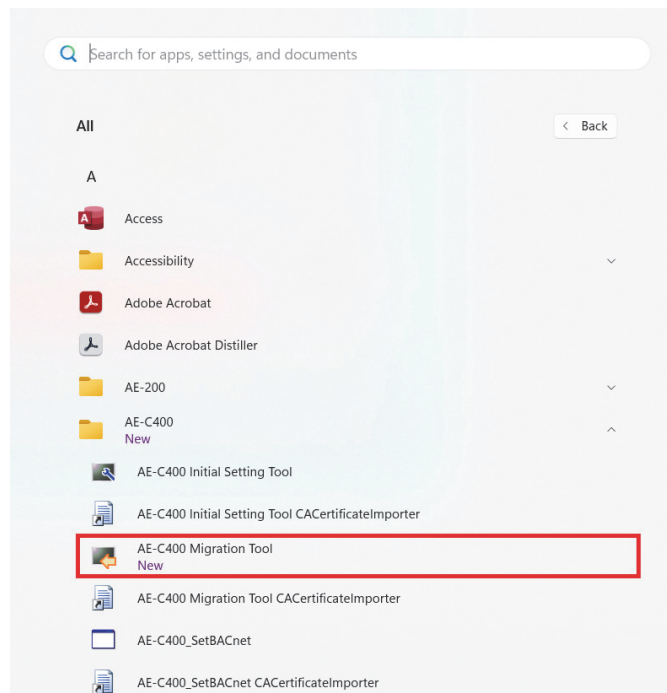

2. At the completion of the startup of the tool, click [(1) Set up migration configuration] on the main screen.
- * By clicking [Open File], you can load the previous settings and monitoring results of the setting data from the previous data file.
- After loading the settings from the file, click [(1) Set up migration configuration] to check the configuration.

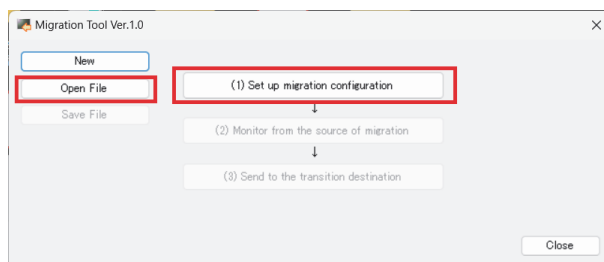

3. On the Migration Configuration Settings screen, select the source and destination models, and enter the source and destination IP addresses.
- An example of the entry of the source and destination models is shown below.

- To migrate from G-50/GB-50 to AE-C

Src			Dst		
SC No.	Model	IP address/Host name	SC No.	Model	IP address/Host name
1	G-50-A/GB-50-A	192.168.1.1	1	AE-C400	192.168.1.1

- To migrate from AG-150A (with EC) to AE-C+EW-C

Src			Dst		
SC No.	Model	IP address/Host name	SC No.	Model	IP address/Host name
1	AG-150A(with EC)	192.168.1.1	1	AE-C400	192.168.1.1
1-1	<input checked="" type="checkbox"/> EC1		2	EW-C50	192.168.1.2
1-2	<input checked="" type="checkbox"/> EC2		3	EW-C50	192.168.1.3
1-3	<input checked="" type="checkbox"/> EC3		4	EW-C50	192.168.1.4

- To migrate from AG-150A (without EC)/GB-50ADA to AE-C

Src			Dst		
SC No.	Model	IP address/Host name	SC No.	Model	IP address/Host name
1	AG-150A(w/o EC)/GB-50ADA	192.168.1.1	1	AE-C400	192.168.1.1

4. Procedure of migrating setting data

4. Upon completion of setting the data source and destination controllers, click [Save].

* The data monitored before this setting will be deleted.

If the configuration has not been changed, click [Close] to close the screen.

5. On a confirmation screen, click [OK].

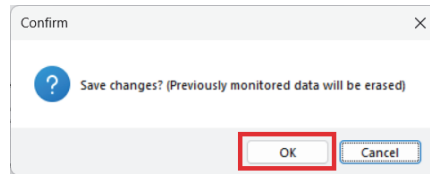

6. Click [Save File] to save the settings.

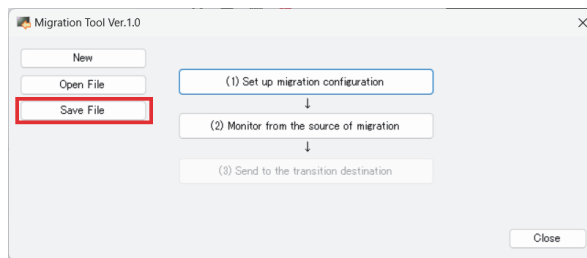

4-3. Monitoring the setting data migrated from the existing controller

Once the centralized controller configuration setting has been completed or loaded from a file, follow the steps below to make settings for monitoring from the existing controller.

Step

1. On the main screen, click [(2) Monitor from the source of migration].

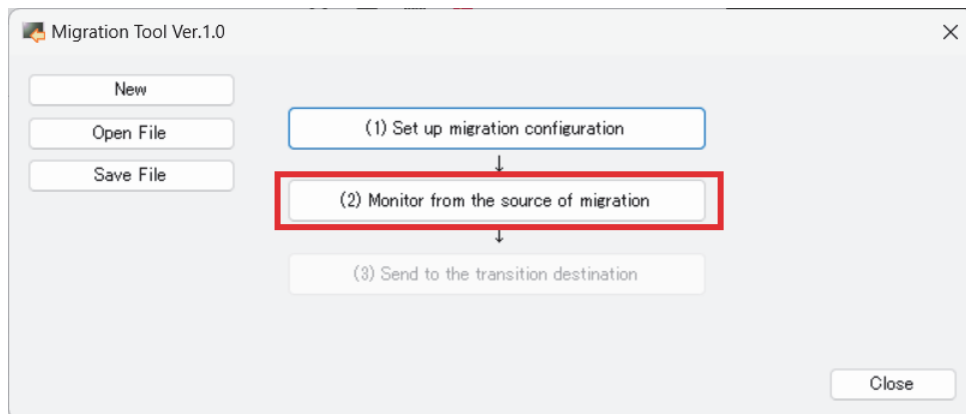

2. On the "Monitor from Migration Source" screen, click [Start Monitoring].



3. On the "Authentication information input" screen, enter the maintenance user/building administrator's ID and password and click [OK].



4. The Monitor screen will appear. Upon completion of the authentication, the screen will close.

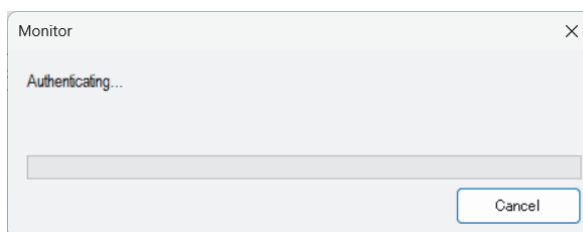

5. Click [Save File] to save the settings and the monitoring results.

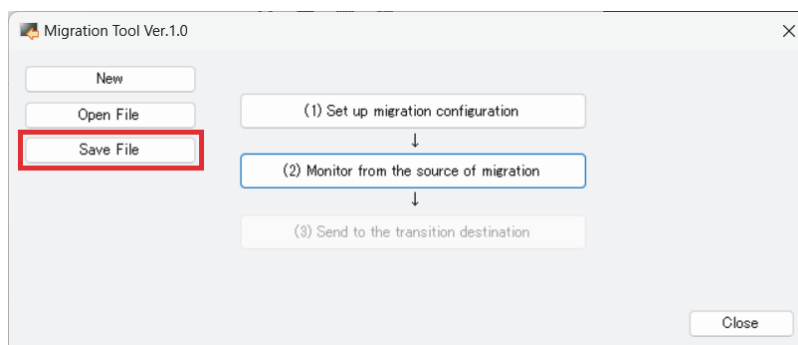

4-4. Removing the existing controller and installing the AE-C/EW-C

If the AE-C/EW-C is installed in the same location as the existing controller, remove the existing controller after the setting data monitoring is completed.

Then install the AE-C/EW-C and set its IP address.

The default IP address of the LAN1 port of the AE-C/EW-C is 192.168.1.1.

If the IP address needs to be changed, refer to the following.

- For the AE-C, refer to the Instruction Book for AE-C/EW-C.
- For the EW-C, refer to the Instruction Book (Detailed operations) for AE-C/EW-C.

4-5. Sending the setting data to the AE-C/EW-C

Upon completion of the installation of the AE-C/EW-C, follow the steps below to send the setting data to the AE-C/EW-C.

Step

1. Click [(3) Send to the transition destination].

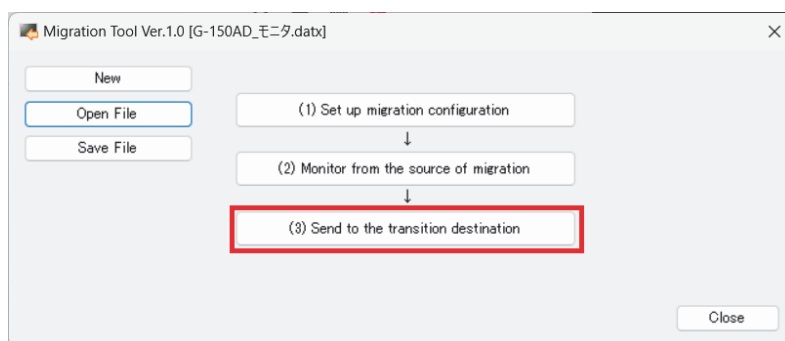

2. On the Send to destination screen, click [Start Sending].



3. On the Authentication information input screen, enter the maintenance user/building administrator's ID and password and click [OK].



4. The Send settings screen will appear. Upon completion of the authentication, the screen will close.

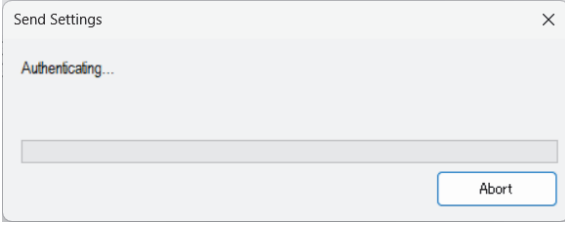

4-6. Editing the setting data of the AE-C/EW-C

After the completion of sending the setting data to the AE-C/EW-C, monitor the settings using the AE-C/EW-C or AE-C/EW-C Initial Setting Tool to check and edit the settings.

5. Troubleshooting

The following are error messages notified by the Migration Tool and their causes and remedies.

Notification timing	Message	Cause	Remedy
After clicking [Start Monitoring] on the Monitor from Migration source screen, or at the start of sending the setting data to the migration destination controller.	Authentication failed for the following centralized controller(s).	The correct user ID or password was not entered.	Enter the correct user ID or password.
		Communication with the controller failed.	Check the LAN connection to the controller and the network settings.
		The user ID or password is unknown.	Contact your dealer for the remedy.
After clicking [Start Monitoring] on the Monitor from Migration source screen.	The version of the following centralized controller(s) is outdated. Please update to the latest version and monitor again.	The software version of the data source controller is old.	Update the software of the data source controller according to "4-1. Preparation."
During communication with AE-C/EW-C	Either the certificate has not been imported or the device you are trying to connect to is not a centralized controller compatible with this tool. Please import the certificate or check the device you are connecting to.	The root CA certificate has not been imported.	Import the root CA certificate according to "3-3. Importing the root CA certificate."

5-1. Log file acquisition method

Copy all folders and files under the log file storage folder of the Migration Tool.

- Log file storage folder: Document\MigrationTool\Log\

6. Trademarks and registered trademarks



MicroSDHC logo is a trademark of SD-3C, LLC.

Android and Google Chrome are trademarks of Google LLC.

BACnet is a trademark of ASHRAE.

IOS is a trademark of Cisco Systems, Inc. and its affiliates in the United States and other countries. iOS is the name of the operating system of Apple Inc. and is used under license.

iPad, iPad mini, iBooks, Safari, macOS, and Apple are trademarks of Apple Inc. registered in the U.S. and other countries.

Microsoft, Windows, Excel, Microsoft Edge, and Windows Server are registered trademarks of Microsoft Corporation in the U.S. and other countries.

MODBUS is a registered trademark of Schneider Electric USA Inc.

Oracle and Java are registered trademarks of Oracle Corporation and/or its affiliates in the U.S. and other countries.

Other company names and product names shown in this manual may be trademarks or registered trademarks of their respective companies.

This product is designed and intended for use in the residential, commercial and light-industrial environment.

The product at hand is based on the following EU regulations:

- Low Voltage Directive 2014/35/EU
- Electromagnetic Compatibility Directive 2014/30/EU

2011/65/EU; (EU) 2015/863; (EU) 2017/2102:

The restriction of the use of certain hazardous substances in electrical and electronic equipment

Please be sure to put the contact address/telephone number
on this manual before handing it to the customer.

MITSUBISHI ELECTRIC CORPORATION

HEAD OFFICE: TOKYO BLDG., 2-7-3, MARUNOUCHI, CHIYODA-KU, TOKYO 100-8310, JAPAN
MANUFACTURER: MITSUBISHI ELECTRIC CORPORATION Air-conditioning & Refrigeration Systems Works
5-66, Tebira 6 Chome, Wakayama-city, 640-8686, Japan