

Air-conditioner Control System

BM ADAPTER BAC-HD150

Instruction Book

Contents

	Page
Safety precautions	2
1. Introduction	3
1.1 Applicable Model	3
1.2 Restrictions/Cautions	4
2. System configurations	5
2.1 Sample system configuration	5
2.2 Group configurations	7
3. Function specifications	8
3.1 Basic Functions	8
3.2 Communication protocol specifications	8
3.3 Objects	9
3.4 Relations between objects and control items	10
3.5 Services	12
3.6 Services per object	14
3.7 Event service specifications	15
4. Setting for power-on for the first time	16
4.1 Caution	16
4.2 Setting up after turning on the power for the first time	16
5. Starting up the BAC-HD150	16
5.1 Starting up the BAC-HD150	16
5.2 Restarting the BAC-HD150	16
5.3 Mode of BAC-HD150	16
6. Switches and LED display	17
6.1 Switch and LED locations	17
6.2 Switch types	17
6.3 LED Types	19
6.4 Switch Setting Display	20
6.5 BAC-HD150 Status and Mode Display	21
6.6 Display Functions	22
6.7 Operation Functions	23
6.8 Error Display	24
6.9 Recommended USB Drives	24
7. On-site adjustment steps (When BAC-HD150 is connected to M-NET)	25
7.1 On-site adjustment flowchart	25
7.2 Preparation for on-site adjustment	26
7.3 Step - 1 Initial setting for air conditioning system	27
7.4 Step - 2 Test run of air conditioning system	28
7.5 Step - 3 Initial settings for the BAC-HD150 related items	29
7.6 Step - 4 Test run of BAC-HD150	30
8. On-site adjustment steps (When BAC-HD150 is connected to PAC-YG50ECA)	31
8.1 On-site adjustment flowchart	31
8.2 Preparation for on-site adjustment	32
8.3 Step - 1 Initial setting for air conditioning system	33
8.4 Step - 2 Test run of BAC-HD150	35

BACnet™ is a registered trade mark of ASHRAE
(American Society of Heating, Refrigerating, and
Air-Conditioning Engineers, INC.).



Safety precautions

Thoroughly read this instruction book before use to ensure safety.

Before using the BAC-HD150, read the Safety Precautions section carefully to ensure proper operation.

These safety precautions must be observed by anyone who operates the BAC-HD150.

Keep the Instruction Book and Installation Manual for future reference. Make sure both manuals are passed on to any future air condition system users.

 WARNING	<p>This symbol indicates that failure to follow the instructions exactly as stated poses the risk of serious injury or death.</p>
 CAUTION	<p>This symbol indicates that failure to follow the instructions exactly as stated poses the risk of injury or damage to the BAC-HD150.</p>

WARNING

The unit must be installed by a dealer or technical representative.

Improper installation by an unqualified person may result in electric shock and fire.

Install in a location that is strong enough to withstand the weight of the unit.

A weak installation area may cause the unit to fall down, resulting in a personal injury.

Only use specified cables. Securely connect each cable so that the weight of the cable is not applied to the connectors.

Loose or improper connections may result in heat generation or fire.

If any abnormality is noticed (e.g., burning smell), stop the operation, turn off the power supply, and contact your dealer or technical representative immediately.

Continuing the operation may result in damage to the BAC-HD150, electric shock, or fire.

Ask your dealer or an authorized technician to move or reinstall the BAC-HD150.

Improper installation may result in an electric shock or fire.

BAC-HD150 must be disposed of properly.

Contact your dealer for proper disposal procedures.

Do not attempt to modify or repair the BAC-HD150.

Modification or improper repair may result in electric shock or fire. Consult your dealer when repairs are necessary.

Stop the operation immediately and notify your dealer if the BAC-HD150 does not operate, or when any abnormality is noticed.

Continuing the operation may result in damage to the BAC-HD150 or fire.

CAUTION

Do not install the BAC-HD150 where there is a risk of leaking flammable gas.

If the leaked gas accumulates around the BAC-HD150, it may ignite and cause an explosion.

Do not wash the BAC-HD150 with water.

Doing so may cause an electric shock or malfunction.

Do not use the BAC-HD150 for specialized applications.

This product is designed exclusively for use with the MITSUBISHI ELECTRIC building air conditioning control system. The use of this product for other purposes may result in malfunctions.

Do not spray insect sprays or sprays with flammable propellants to the BAC-HD150.

To avoid the risk of fire or explosion, do not place flammable sprays near the BAC-HD150 or spray them directly on the BAC-HD150.

Do not apply mechanical shock to BAC-HD150.

Do not use the BAC-HD150 in an environment high in oil, steam, or sulfuric gas.

These substances may have adverse effects on the performance of the BAC-HD150 or damage its parts.

Operate the BAC-HD150 within the temperature range specification.

The use of controller outside of its specification may result in serious damage to the BAC-HD150. Be sure to check the temperature range specification in the Installation Manual.

Use a security device such as a VPN router when connecting the BAC-HD150 to the Internet to prevent unauthorized access.

If no security devices are installed, the operation settings may be changed by an unauthorized person without the knowledge of the user.

1 Introduction

1.1 Applicable Model

BAC-HD150 have functions to monitor and operate air conditioning units (excl. certain models).

Table: Models and available functions

Model	Function (Monitor/Operation)	
CITY MULTI	S series	○
	Y series	○
	HP series	○
	R2 series	○
	WY series	○
	WR2 series	○
LOSSNAY	○	
OA Processing unit	○	
A-control unit (Mr. Slim)	○ (Requires an adapter)	
AK-control unit (Mr. Slim)	x	
K-control unit	○ (Requires a converter)	
Room air conditioner (RAC)	x	
Air To Water Booster unit/Air To Water HEX unit	○	

○: Supported

x: Not supported

1.2 Restrictions/Cautions

Restrictions and Cautions for BAC-HD150 are as follows.

(1) Restrictions on the system configuration

(a) When BAC-HD150 is connected to M-NET

	Number of connectable units	Notes
M-NET	One line only	
Indoor unit	50 units max./M-NET	Includes all IC, LC, AIC, KIC, BU, AU.

Symbol IC : Indoor unit
 Includes the FU (OA processing units) that are configured in the group but not interlocked with the indoor units.
 AIC : A-control indoor unit
 BU : Air To Water Booster unit
 LC : LOSSNAY
 KIC : K-control indoor unit
 AU : Air To Water HEX unit

(b) When BAC-HD150 is connected to PAC-YG50ECA (Expansion Controller)

	Number of connectable units	Notes
PAC-YG50ECA	3 units max.	Software Version : 1.30 or later
AG-150A	1 or 2 units	Software Version : 2.30 or later
BAC-HD150	1 unit	Software Version : 2.00 or later
Indoor unit	150 units max. (50 units max. / PAC-YG50ECA)	Includes all IC, LC, AIC, KIC, BU, AU.

- Restrictions on the DB No.
 Controllers (PAC-YG50ECA, AG-150A and BAC-HD150) with different DB No. cannot be connected to each other. When DB No. on the controllers is different, update the software version of the controllers. Refer to section 3-3 "System in which BAC-HD150 is connected to PAC-YG50ECA (Expansion Controller)" in the BAC- HD150 Installation Manual for information about DB No.

(2) Connecting AG-150A

- When connecting BAC-HD150 to PAC-YG50ECA, connect AG-150A to set the M-NET address, group, and interlocked operation with LOSSNAY for PAC-YG50ECA.

(3) Supports for errors

- It is recommended to recover the system immediately when errors related to air conditioning are displayed on the building management system.

(4) Operation during power failure

- When BAC-HD150 needs to be operated during power failure, a power backup device such as UPS (Uninterruptible Power Supply) is recommended to be installed.

(5) Functions

- Due to continuing improvement, specifications are subject to change without notice.

(6) Models in a group

- BAC-HD150 monitors and controls indoor units for each group (*1).
 To group multiple indoor units, use the same models in a group.

*1 : Group has two types: a unit in a group or multiple units in a group.

2 System configurations

2.1 Sample system configuration

(1) Sample system configuration when BAC-HD150 is connected to M-NET

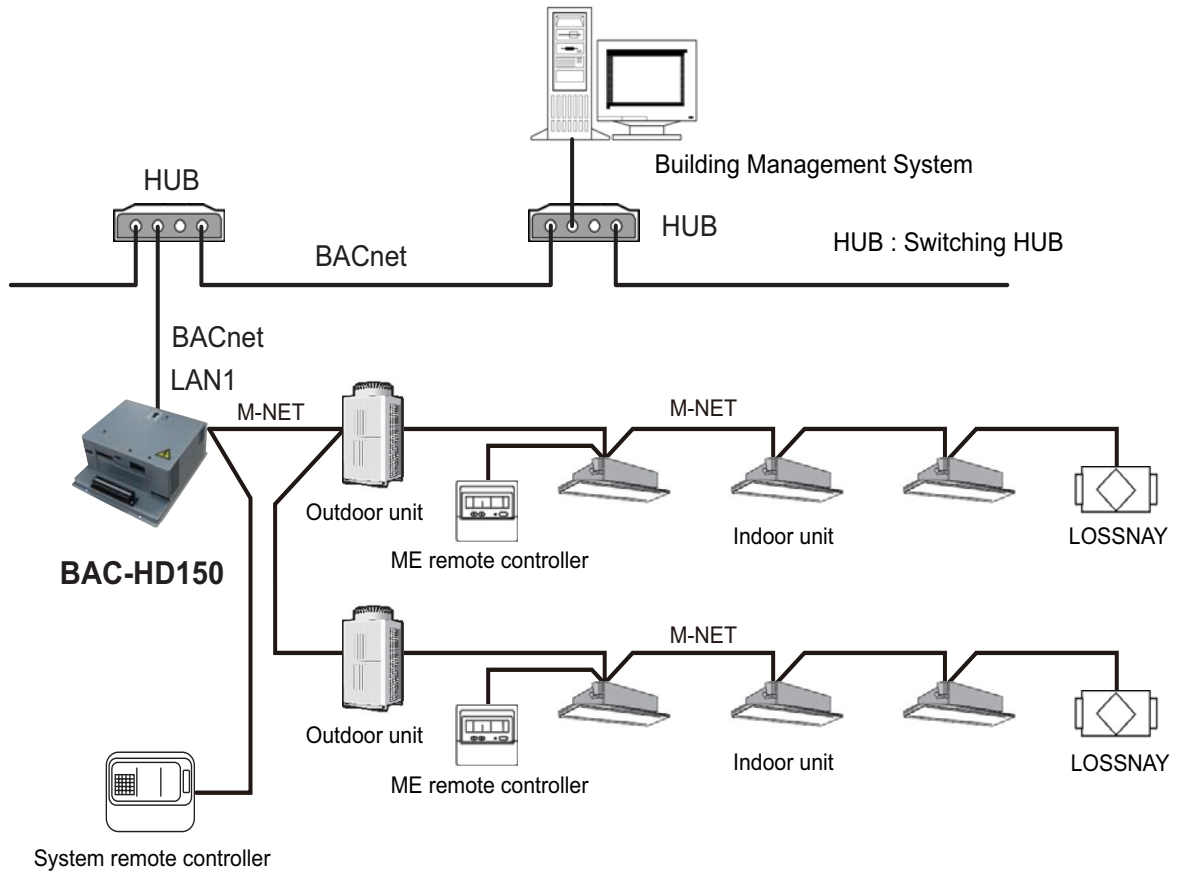

M-NET: Mitsubishi Electric air conditioning control line

(2) Sample system configuration when BAC-HD150 is connected to PAC-YG50ECA

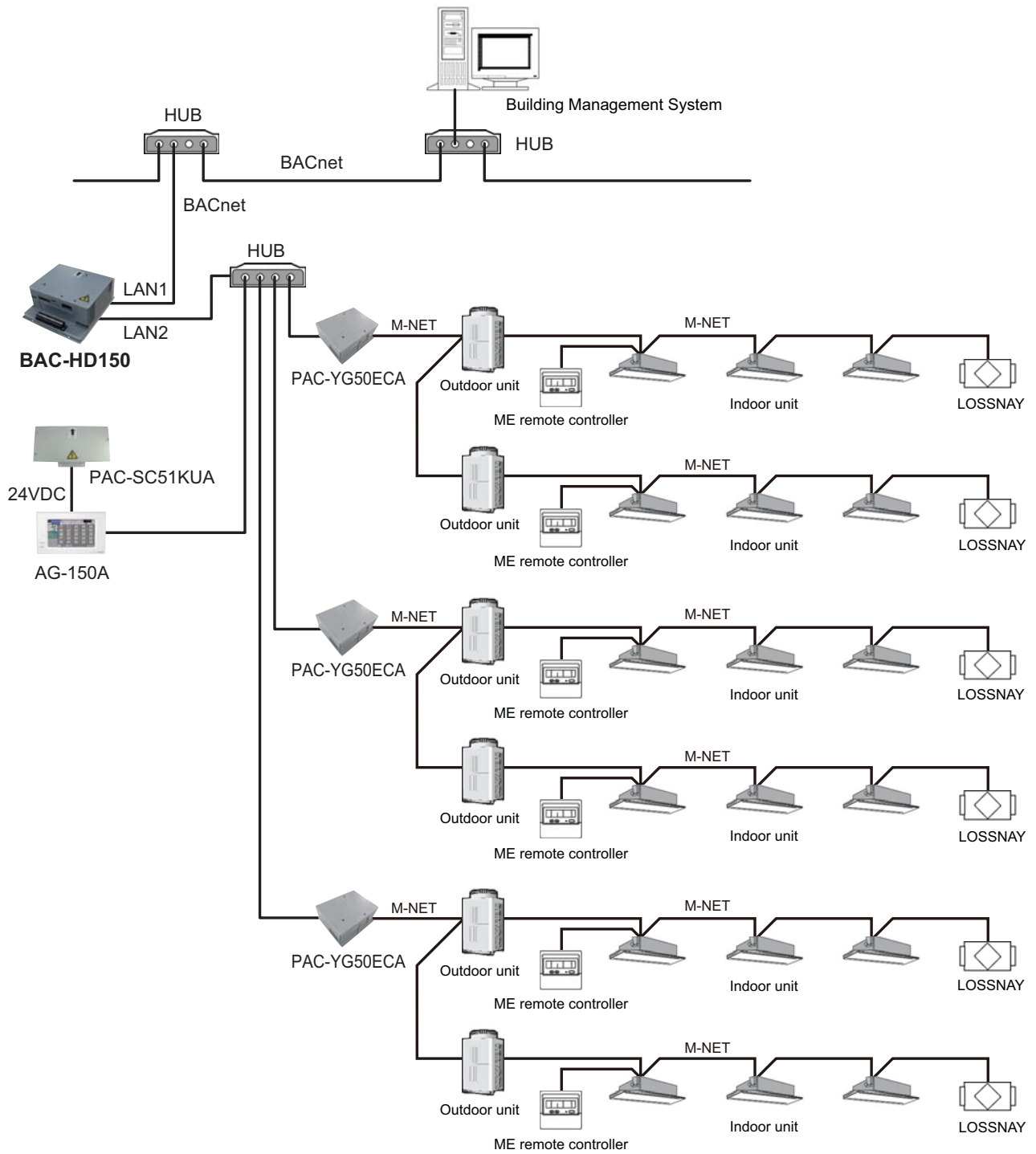

M-NET: Mitsubishi Electric air conditioning control line

2.2 Group configurations

BACnet controls each group.

BACnet control hierarchy consists of M-NET number + Group number + Member number.

Refer to “3.4 Relations between objects and control items” for member number details.

(1) M-NET number

(a) When BAC-HD150 is connected to M-NET

Fixed to 01

(b) When BAC-HD150 is connected to PAC-YG50ECA

M-NET number (01-03)

(2) Group number

Multiple indoor units (IC) can be controlled as a target group. Group number range: 1-50

(3) Member number

Corresponds to Monitor/Operation items of air conditioners

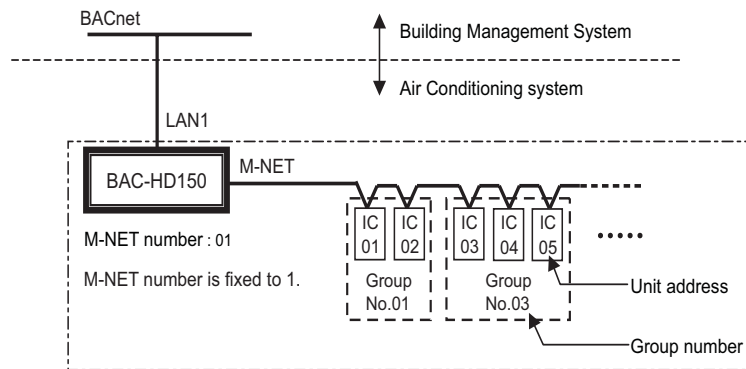

BAC-HD150 is connected to M-NET.

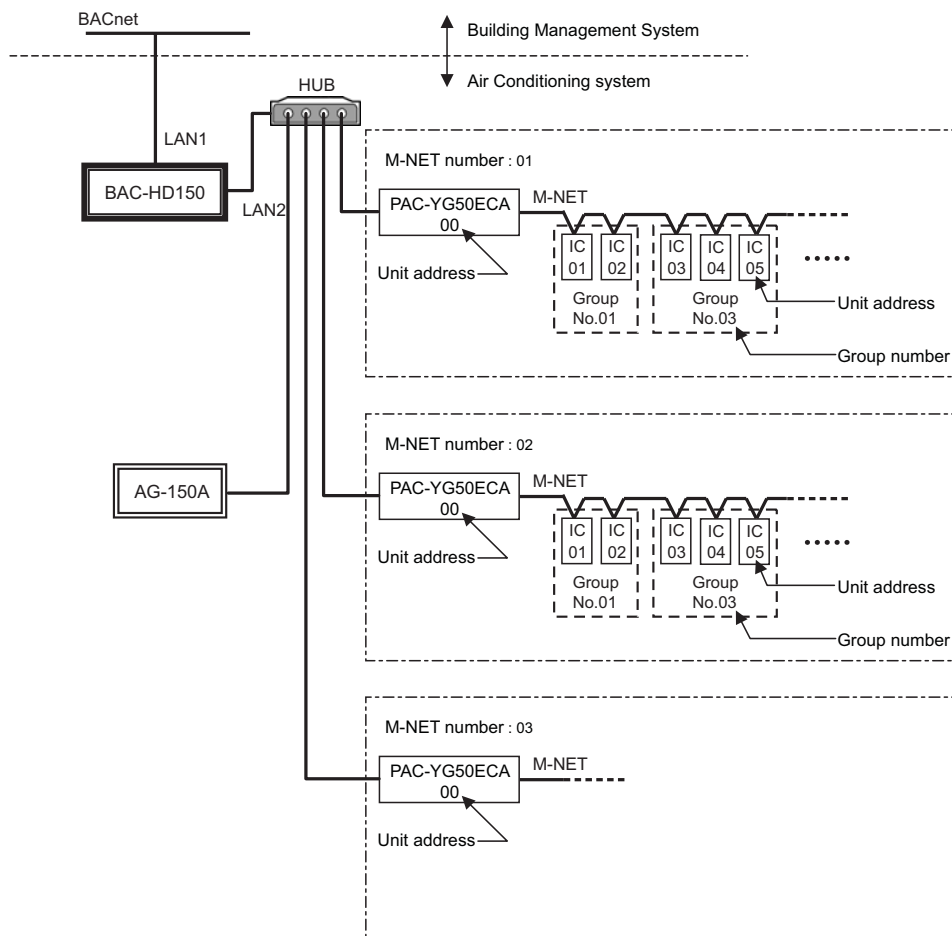

BAC-HD150 is connected to PAC-YG50ECA.

3 Function specifications

3.1 Basic Functions

BAC-HD150 has functions that communication from an air conditioning system is protocol converted to BACnet communication, that command from a Building Management System is converted and transmitted to an air conditioning system, and that air conditioning system status data is collected and the status change is detected. BAC-HD150 also collects data on air conditioning units operation status and transmits the data upon request from the building management system. Refer to "3.4 Relations between objects and control items" for control item of BAC-HD150.

3.2 Communication protocol specifications

(1) General descriptions of protocol

BACnet/IP which applied to ANSI/ASHRAE 135-2004 correspondingly on UDP/IP of Ethernet is used.

Ethernet header	IP header	UDP header	BVLL header	NPCI	APDU
-----------------	-----------	------------	-------------	------	------

Ethernet is a registered trademark of Fuji Xerox, Inc.

(2) Ethernet header

Physical layer: Ethernet

Transmission medium: 10BASE-T

(3) IP header

Class C private address is recommended. (*1) Subnet Mask: 255.255.255.0

*1: Recommended value (range): [192.168.1.1] - [192.168.254.254]

Do not use [192.168.0.0] and [192.168.255.255] as a device address.

(4) UDP header

The default UDP port of unicast and broadcasting is set to 47808 (0xBAC0).

(5) BVLL header (BVLL: BACnet Virtual Link Layer)

BVLC type (1 octet) Fixed to 0x81 (BVLL against BACnet/IP)

BVLC function (1 octet) Unicast 0x0A

Broadcast 0x0B

BVLC length (2 octets) Variable (BVLL header (4 octets) + NPCI data length + APDU data length)

(Typical examples are listed above. Refer to ANSI/ASHRAE 135-2004 for details.)

(6) NPCI (NPCI: Network Layer Protocol Control Information)

Version (1 octet) Fixed to 0x01

Control (1 octet) Response is received. 0x04

No response 0x00

(Typical examples are listed above. Refer to ANSI/ASHRAE 135-2004 for details.)

(7) APDU (APDU: Application Layer Protocol Data Unit)

Data: 1024 octets or less

(Refer to ANSI/ASHRAE 135-2004 for details.)

3.3 Objects

Supported object list is shown below.

Object type		Abbreviation	Support	Control item	Notes
Accumulator	23	–	–		
Analog Input	0	AI	○	Room Temp [Water Temp]	
Analog Output	1	–	–		
Analog Value	2	AV	○	Set Temp [Set Water Temp]	
Averaging	18	–	–		
Binary Input	3	BI	○	On Off State Alarm Signal Filter Sign [Circulating Water Exchange Sign] M-NET Communication State Expansion Controller Communication State	
Binary Output	4	BO	○	On Off Setup	
Binary Value	5	BV	○	Filter Sign Reset [Circulating Water Exchange Sign Reset] Prohibition On Off Prohibition Mode Prohibition Filter Sign Reset [Prohibition Circulating Water Exchange Sign Reset] Prohibition Set Temperature System Forced Off	
Calendar	6	–	–		
Command	7	–	–		
Device	8	DEV	○	Device object of BAC-HD150	
Event Enrollment	9	–	–		
File	10	–	–		
Group	11	–	–		
Life Safety Point	21	–	–		
Life Safety Zone	22	–	–		
Loop	12	–	–		
Multi-state Input	13	MI	○	Error Code Operational Mode State Fan Speed State Air Direction State Ventilation Mode State Air To Water Mode State	
Multi-state Output	14	MO	○	Operational Mode Setup Fan Speed Setup Air Direction Setup Ventilation Mode Setup Air To Water Mode Setup	
Multi-state Value	19	–	–		
Notification Class	15	CLS	○	Object for Event notification	
Program	16	–	–		
Pulse Converter	24	–	–		
Schedule	17	–	–		
Trend Log	20	–	–		

- : Supported
- : Not supported

Inside the brackets indicates control item for BU or AU group. (Refer to section 1.2 Restrictions/Cautions.)

3.4 Relations between objects and control items

Object ID consists of object type + instance number.

Instance number consists of M-NET number, air conditioner group number, and member number.

31

22 21

0

BACnet object type	Instance number
--------------------	-----------------

BACnet object type : Refer to the object type as shown in the table below.

Instance number (6 digits in decimal notation) : xx xx xx

- Member number (01-99)
- Group number (01-50, 99)
- M-NET number (01-03)

Control item	Object type	Instance number	Unit					Notes
			Inactive	Active				
			Text-1	Text-2	Text-3	Text-4	Text-5	
On Off Setup	BO	xxxx01	Stop	Run				
On Off State	BI	xxxx02	Stop	Run				
Alarm Signal	BI	xxxx03	Normal	Error				
Error Code	MI	xxxx04	Normal	01: Normal 02: Other errors 03: Refrigeration system fault 04: Water system error 05: Air system error		06: Electronic system error 07: Sensor fault 08: Communication error 09: System error		
Operational Mode Setup	MO	xxxx05	Cooling	Heating	Fan	Auto	Dry	
Operational Mode State	MI	xxxx06	Cooling	Heating	Fan		Dry	
Fan Speed Setup	MO	xxxx07	Low	High	Mid 2	Mid 1		
Fan Speed State	MI	xxxx08	Low	High	Mid 2	Mid 1		
Room Temp [Water Temp]	AI	xxxx09	°F/°C					
Set Temp [Set Water Temp]	AV	xxxx10	°F/°C					
Filter Sign [Circulating Water Exchange Sign]	BI	xxxx11	OFF	ON				
Filter Sign Reset [Circulating Water Exchange Sign Reset]	BV	xxxx12	Reset	Void				
Prohibition On Off	BV	xxxx13	Permit	Prohibit				
Prohibition Mode	BV	xxxx14	Permit	Prohibit				
Prohibition Filter Sign Reset [Prohibition Circulating Water Exchange Sign Reset]	BV	xxxx15	Permit	Prohibit				
Prohibition Set Temperature	BV	xxxx16	Permit	Prohibit				
M-NET Communication State	BI	xxxx20	Normal	Error				
System Forced Off	BV	xxxx21 999921	Reset	Execute				
Air Direction Setup	MO	xxxx22	Horizontal	Downblow 60%	Downblow 80%	Downblow 100%	Swing	
Air Direction State	MI	xxxx23	Horizontal	Downblow 60%	Downblow 80%	Downblow 100%	Swing	
Ventilation Mode Setup	MO	xxxx35	Heat exchange	Bypass	Auto			
Ventilation Mode State	MI	xxxx36	Heat exchange	Bypass	Auto			
Air To Water Mode Setup	MO	xxxx37	Heating	Heating ECO	Hot Water	Antifreeze	Cooling	
Air To Water Mode State	MI	xxxx38	Heating	Heating ECO	Hot Water	Antifreeze	Cooling	
Expansion Controller Communication State	BI	xx9981	Normal	Error				

Inside the brackets indicates control item for BU or AU group. (Refer to section 1.2 Restrictions/Cautions.)

Control item	Object type	Instance number	Model group			Note
			IC Group *4	LC Group	BU.AU Group	
On Off Setup	BO	xxxx01	○	○	○	
On Off State	BI	xxxx02	○	○	○	
Alarm Signal	BI	xxxx03	○	○	○	
Error Code	MI	xxxx04	○	○	○	
Operational Mode Setup	MO	xxxx05	○	–	–	*1
Operational Mode State	MI	xxxx06	○	–	–	*1
Fan Speed Setup	MO	xxxx07	○	○	–	*2
Fan Speed State	MI	xxxx08	○	○	–	*2
Room Temp [Water Temp]	AI	xxxx09	○	–	○	
Set Temp [Set Water Temp]	AV	xxxx10	○	–	○	*3
Filter Sign [Circulating Water Exchange Sign]	BI	xxxx11	○	○	○	
Filter Sign Reset [Circulating Water Exchange Sign Reset]	BV	xxxx12	○	○	○	
Prohibition On Off	BV	xxxx13	○	○	○	*5
Prohibition Mode	BV	xxxx14	○	–	○	*5
Prohibition Filter Sign Reset [Prohibition Circulating Water Exchange Sign Reset]	BV	xxxx15	○	○	○	*6
Prohibition Set Temperature	BV	xxxx16	○	–	○	*5
M-NET Communication State	BI	xxxx20	○	○	○	
System Forced Off	BV	xxxx21 999921	○	○	○	
Air Direction Setup	MO	xxxx22	○	–	–	
Air Direction State	MI	xxxx23	○	–	–	
Ventilation Mode Setup	MO	xxxx35	–	○	–	
Ventilation Mode State	MI	xxxx36	–	○	–	
Air To Water Mode Setup	MO	xxxx37	–	–	○	
Air To Water Mode State	MI	xxxx38	–	–	○	
Expansion Controller Communication State	BI	xx9981	–	–	–	

- : Controllable
 – : Not controllable

Inside the brackets indicates control item for BU or AU group. (Refer to section 1.2 Restrictions/Cautions.)

*1: When “Use Mode Type Dry” is set to “enabled” by using BAC-HD150 Setting Tool (abbreviated to Setting Tool below), “Dry” can be used.

*2: When “Use Fan Speed Type Mid1/Mid2” is set to “enabled” by using Setting Tool, “Mid1” and “Mid2” can be used.

*3: The settable temperature ranges are as follows.

(The following tables show only the representative ranges. The settable range varies with the models.)

*4: Includes the FU (OA processing units) that are configured in the group but not interlocked with the indoor units.

*5: In the “ON/OFF”, “Mode”, “Set temp” prohibit functions, only “ON/OFF” prohibit function can be used with K-control indoor units. “Mode” or “Set temp” prohibit functions synchronize with the state of “ON/Off” prohibit function.

*6: K-control indoor unit does not support “Filter Sign Reset” prohibit function.

(1) Indoor unit

Mode	Cooling	Heating	Auto	Dry
Standard temp model	19-30°C	17-28°C	19-28°C	19-30°C
Mid temp model	14-30°C	17-28°C	17-28°C	14-30°C

(2) Air To Water

Mode	Heating	Heating ECO	Hot Water	Anti-freez	Cooling
Booster unit (BU)	30-50°C	30-45°C	30-70°C	10-45°C	Invalid
HEX unit (AU)	30-45°C	30-45°C	Invalid	10-45°C	10-30°C

3.5 Services

The following table shows the supported services.

Service	Initiate request	Execute request
1. Alarm and Event Services		
(1) Acknowledge Alarm Service	-	-
(2) Confirmed COV Notification Service	○	-
(3) Confirmed Event Notification Service	○	-
(4) Get Alarm Summary Service	-	-
(5) Get Enrollment Summary service	-	-
(6) Get Event Information Service	-	○
(7) Life Safety Operation Service	-	-
(8) Subscribe COV Service	-	○
(9) Subscribe COV Property Service	-	-
2. File Access Services		
(1) Atomic Read File Service	-	-
(2) Atomic Write File Service	-	-
3. Object Access Services		
(1) Add List Element Service	-	○
(2) Remove List Element Service	-	○
(3) Create Object Service	-	-
(4) Delete Object Service	-	-
(5) Read Property Service	-	○
(6) Read Property Conditional Service	-	-
(7) Read Property Multiple Service	-	○
(8) Read Range Service	-	-
(9) Write Property Service	-	○
(10) Write Property Multiple Service	-	○
4. Remote Device Management Services		
(1) Device Communication Control Service	-	○
(2) Confirmed Private Transfer Service	-	-
(3) Confirmed Text Message Service	-	-
(4) Reinitialize Device Service	-	-
5. Virtual Terminal Services		
(1) VT-Open Service	-	-
(2) VT-Close Service	-	-
(3) VT-Data Service	-	-

○ : Supported

- : Not supported

Initiate request: Provides services

Execute request: Receives and uses services

Service	Initiate request	Execute request
6. Security Services		
(1) Authenticate Service	-	-
(2) Request Key Service	-	-
7. Unconfirmed Services		
(1) I-Am	○	○
(2) I-Have	○	-
(3) Unconfirmed COV Notification Service	○	-
(4) Unconfirmed Event Notification Service	○	-
(5) Unconfirmed Private Transfer Service	-	-
(6) Unconfirmed Text Message Service	-	-
(7) Time Synchronization Service	-	○
(8) UTC Time Synchronization Service	-	-
(9) Who-Has	-	○
(10) Who-Is	○	○

○ : Supported

- : Not supported

Initiate request: Provides services

Execute request: Receives and uses services

3.6 Services per object

The following table shows the supported service per object.

Service	Object type	Device	Analog Input	Analog Value	Binary Input	Binary Output	Binary Value	Multi-State Input	Multi-State Output	Notification Class	Notes
Confirmed COV Notification	INIT		△	△	△	△	△	△	△		
	EXEC										
Confirmed Event Notification	INIT		△		△	△					
	EXEC										
Get Event Information	INIT										
	EXEC	○									
Subscribe COV	INIT										
	EXEC	○									
Add List Element	INIT										
	EXEC									○	
Remove List Element	INIT										
	EXEC									○	
Read Property	INIT										
	EXEC	○	○	○	○	○	○	○	○	○	
Read Property Multiple	INIT										
	EXEC	○	○	○	○	○	○	○	○	○	
Write Property	INIT										
	EXEC	○	○	○	○	○	○	○	○	○	
Write Property Multiple	INIT										
	EXEC	○	○	○	○	○	○	○	○	○	
Device Communication Control	INIT										
	EXEC	○									
I-Am	INIT	○									
	EXEC	○									
I-Have	INIT	○									
	EXEC										
Unconfirmed COV Notification	INIT		△	△	△	△	△	△	△		
	EXEC										
Unconfirmed Event Notification	INIT		△		△	△					
	EXEC										
Time Synchronization	INIT										
	EXEC	○									
Who-Has	INIT										
	EXEC	○									
Who-Is	INIT	○									
	EXEC	○									

INIT: Provides services

EXEC: Receives and uses services

○: Supported

△: Changeable using setting data

3.7 Event service specifications

The following table shows the supported notifications for each object.

The Event notification is used to notify the Alarm and Event. The COV notification is used to notify the change of Present Value.

Selection of “Confirmed” or “Unconfirmed” can be made for each notification target.

Control item	Object	Event notification	COV notification	Notes
On Off Setup	BO_ xxxx01	○	○	
On Off State	BI_ xxxx02	○	○	
Alarm Signal	BI_ xxxx03	○	○	
Error Code	MI_ xxxx04	–	○	
Operational Mode Setup	MO_ xxxx05	–	○	
Operational Mode State	MI_ xxxx06	–	○	
Fan Speed Setup	MO_ xxxx07	–	○	
Fan Speed State	MI_ xxxx08	–	○	
Room Temp [Water Temp]	AI_ xxxx09	○	○	
Set Temp [Set Water Temp]	AV_ xxxx10	–	○	
Filter Sign [Circulating Water Exchange Sign]	BI_ xxxx11	○	○	
Filter Sign Reset [Circulating Water Exchange Sign Reset]	BV_ xxxx12	–	○	
Prohibition On Off	BV_ xxxx13	–	○	
Prohibition Mode	BV_ xxxx14	–	○	
Prohibition Filter Sign Reset [Prohibition Circulating Water Exchange Sign Reset]	BV_ xxxx15	–	○	
Prohibition Set Temperature	BV_ xxxx16	–	○	
M-NET Communication State	BI_ xxxx20	○	○	
System Forced Off	BV_ xxxx21 BV_ 999921	–	○	
Air Direction Setup	MO_ xxxx22	–	○	
Air Direction State	MI_ xxxx23	–	○	
Ventilation Mode Setup	MO_ xxxx35	–	○	
Ventilation Mode State	MI_ xxxx36	–	○	
Air To Water Mode Setup	MO_ xxxx37	–	○	
Air To Water Mode State	MI_ xxxx38	–	○	
Expansion Controller Communication State	BI_ xx9981	○	○	
Notification Class	CLS_ xxxxxx	–	–	
Device	DEV_ xxxxxx	–	–	

○: Notification is settable using setting data

–: Notification is not settable

Inside the brackets indicates control item for BU or AU group. (Refer to section 1.2 Restrictions/Cautions.)

4 Setting for power-on for the first time

4.1 Caution

LAN1 port is used for BACnet connection. LAN2 port is used for PAC-YG50ECA, AG-150A and Setting Tool connection. LAN IP address for BAC-HD150 is set to the following addresses at factory setting.

- LAN1 192.168.1.254
- LAN2 192.168.200.212

The addresses may overlap the addresses that are assigned to other devices. When turning on the power for the first time after installation, turn on the power to BAC-HD150 with LAN1 and LAN2 cables disconnected. (If the addresses overlap, communications cannot be performed properly via BAC-HD150 or other devices.)

Connect the LAN2 cable for BAC-HD150 to use Setting Tool. Connect the LAN1 cable after IP addresses (LAN1 and LAN2) are set by using Setting Tool.

4.2 Setting up after turning on the power for the first time

Make initial setting using Setting Tool after the power to BAC-HD150 is turned on.

Refer to the Instruction Book that came with Setting Tool for details about Initial Setting.

5 Starting up the BAC-HD150

5.1 Starting up the BAC-HD150

BAC-HD150 starts up when the power is turned on.

BACnet communication and M-NET/Expansion Controller communication (*1) are performed after startup.

*1 When BAC-HD150 is connected to M-NET, M-NET communication is performed.

When BAC-HD150 is connected to PAC-YG50ECA (Expansion Controller), Expansion Controller communication is performed.

5.2 Restarting the BAC-HD150

BAC-HD150 restarts when SW403 is pressed.

If the system settings are changed for the system to which Expansion Controllers (PAC-YG50ECA) are connected, be sure to restart the BAC-HD150 to reflect the changes.

5.3 Mode of BAC-HD150

BAC-HD150 has "Online" mode and "Offline" mode.

"Online" mode is an operation mode to perform BACnet communication(*2) and M-NET/Expansion Controller communication.

"Offline" mode is a maintenance mode in which BACnet communication is not performed.

It is the mode in which the Setting Tool can configure data settings to the BAC-HD150.

Mode change between "Online" and "Offline" are as follows.

*2 If the maximum number of groups and items are set, it may take approximately 10 minutes until BACnet becomes ready for communication in the following cases: After the power is turned on or when the mode is switched from Offline to Online.

If BAC-HD150 is configured to control or monitor a large number of groups and/or items, the BAC-HD150 may go into the Online mode before BACnet is ready for communication.

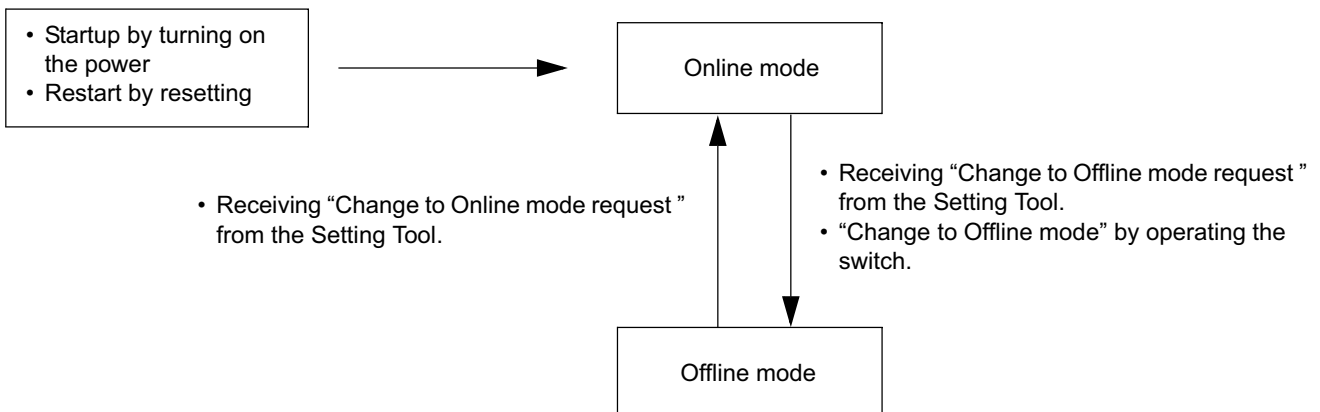

Note:

In the following cases, the system will temporarily go into the INITIAL mode. The greater the number of groups or control/monitor items there are in the settings, the longer the INITIAL mode will last. (Maximum 5 minutes)

- After the power is turned on
- When switching from the Offline mode to the Online mode
- When the "Put Setting" command was executed from the Setting Tool.

6 Switches and LED display

6.1 Switch and LED locations

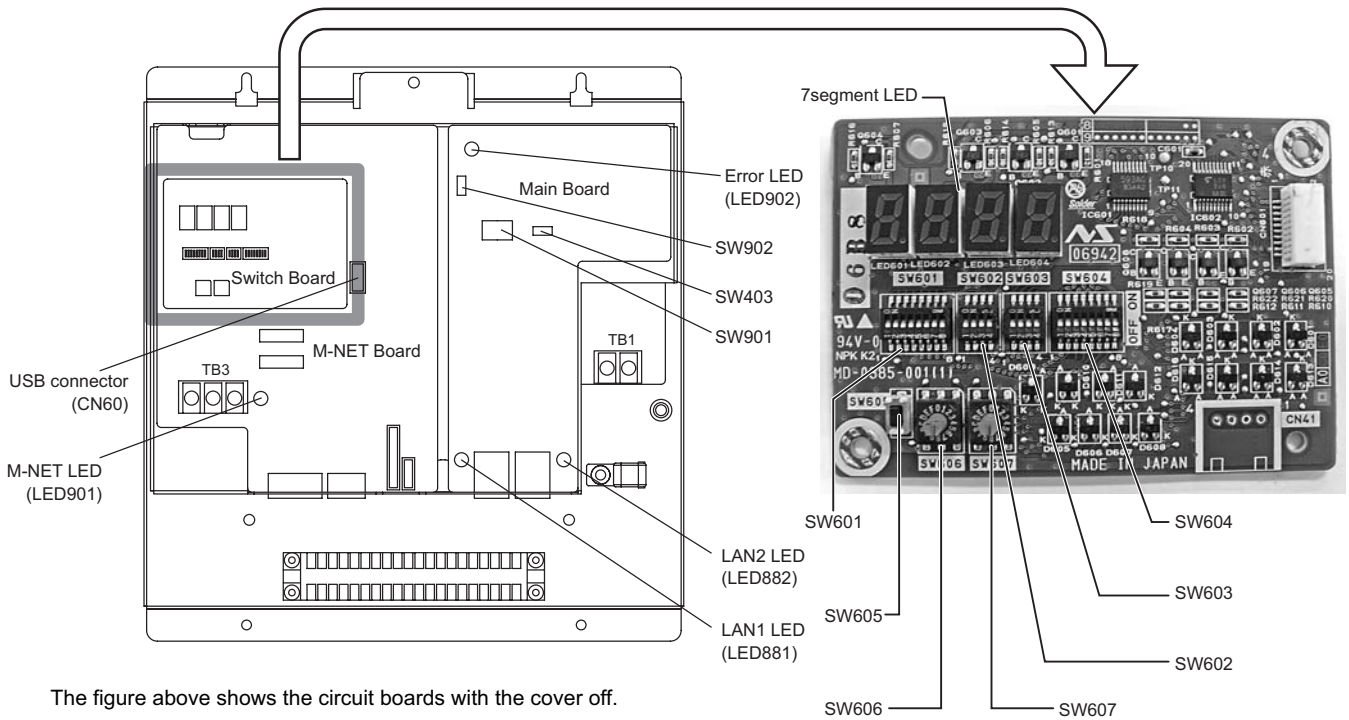

6.2 Switch types

(1) Dip switches

Dip switches include SW601, SW602, SW603, SW604, SW901, and SW902.
(SW603 and SW604 are spare switches.)

(a) SW601

SW601 is used to display the BAC-HD150 status and operation mode on the 7segment LED.
(Refer to section 6.6 Display Functions for details .)

(b) SW602

SW602 is used to operate BAC-HD150.
(Refer to section 6.7 Operation Functions for details.)

(c) SW901

Set SW901 to 00000100. (0: OFF, 1: ON)
(Set No. 6 to ON.)

(d) SW902

Leave all switches to OFF.

(2) Rotary switches

Rotary switches include SW606 and SW607.

SW606 and SW607 are used to operate BAC-HD150.

(Refer to section 6.7 Operation Functions for details.)

The arrow on the rotary switch indicates the current setting of the switch.

(The available setting range is 0 through F. The figure below shows representative values only.)

The figure below shows a rotary switch that is set to 0.

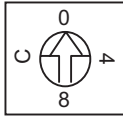

(3) Push switches

Push switches include SW605 and SW403.

(a) SW605

SW605 is used to use the display and operation functions.

(Refer to sections 6.6 Display Functions and 6.7 Operation Functions for details.)

(b) SW403

Press SW403 to restart BAC-HD150.

CAUTION:

Pressing SW403 will restart BAC-HD150. Use caution not to accidentally push this switch, for the Building Management System may falsely detect the communication with BAC-HD150 as an error.

6.3 LED Types

(1) LED

LEDs include M-NET LED, LAN1 LED, LAN2 LED, and Error LED.

LED name	Display items	Display contents
M-NET	Device power supply status and M-NET communication status	Lit : Powered
		Unlit : Not powered
		Blink: M-NET transmission in progress
LAN1	LAN 1 (BACnet communication) status	Lit : Linking
		Unlit : Not linked
		Blink: Transmitting
LAN2	LAN 2 (Expansion Controller communication) status	Lit : Linking
		Unlit : Not linked
		Blink: Transmitting
Error	BACnet communication status	Lit : BACnet communication error
		Unlit : Normal BACnet communication

(2) 7segment LED

The 7segment LED displays the BAC-HD150 status and modes during normal operation. (Refer to section 6.5 BAC-HD150 Status and Mode Display.)

This LED also indicates the display and operation functions that are being executed.

(Refer to sections 6.6 Display Functions and 6.7 Operation Functions for details.)

Shown below are the codes that appear in the 7segment LED that correspond to alphabetic letters.

A B C D E F G H I J K L M N O P Q R S T U V W X Y Z
 A b c d E F G h i j k l m n o p q r s t u v w x y z

6.4 Switch Setting Display

The settings of SW601 and SW602 will appear in the two upper digits (the positions that correspond to “a” and “b” in the figure below) of the 7segment LED in hexadecimal notation.

7segment LED

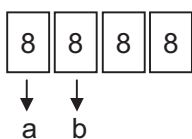

If one or more of the switches on SW601 are set to ON, the settings of switches 1 through 4 will appear in the position that corresponds to “a,” and 5 through 8 in position “b” in the figure above.

If one or more of the switches on SW602 are set to ON, the settings of switches 1 through 4 will appear in the position that corresponds to “b” in the figure above.

(“C” will appear in the position that corresponds to “a” in the figure above.)

If any one of the switches on both SW601 and SW602 are set to ON (*1), “Er11” will appear in the 7segment LED.

*1 : Any combinations of switch settings other than the combination in which all switches are set to OFF.

The following table shows the switch settings and the corresponding data in the hexadecimal notation system.

No.	SW601 SW602 [0 : OFF, 1 : ON]				Data in hexadecimal notation
	1	2	3	4	
	5	6	7	8	
0	0	0	0	0	0
1	0	0	0	1	1
2	0	0	1	0	2
3	0	0	1	1	3
4	0	1	0	0	4
5	0	1	0	1	5
6	0	1	1	0	6
7	0	1	1	1	7
8	1	0	0	0	8
9	1	0	0	1	9
10	1	0	1	0	A
11	1	0	1	1	B
12	1	1	0	0	C
13	1	1	0	1	D
14	1	1	1	0	E
15	1	1	1	1	F

6.5 BAC-HD150 Status and Mode Display

BAC-HD150 status and mode will appear in the 7segment LED when SW601 and SW602 are both set to OFF and SW606 and SW607 are both set to "0".

LD1	CPU status	Lit : Normal
		Unlit : Error
LD2	Expansion Controller communication status	Lit : Error
		Unlit : Normal
LD3	BACnet communication status	Lit : Error
		Unlit : Normal
LD4	Error status	Lit : At least one air conditioning unit is in error.
		Unlit : All units are normal.
LD5	M-NET/Expansion Controller startup status(*1)	Unlit : Startup completed.
		Blink : Starting up
LD6	(Not assigned)	–
LD7	BAC-HD150 mode	Lit : Offline mode
		Unlit : Online mode
LD8	BACnet communication service status	Lit : Communication lock (setting other than Enable)
		Unlit : Communication allowed (Enable)

*1 When BAC-HD150 is connected to M-NET, LD5 displays the M-NET startup status.

When BAC-HD150 is connected to PAC-YG50ECA (Expansion Controller), LD5 displays the Expansion Controller communication startup status.

When BAC-HD150 is connected to multiple PAC-YG50ECA (Expansion Controllers), LD2 and LD5 display the summarized status of all PAC-YG50ECA controllers.

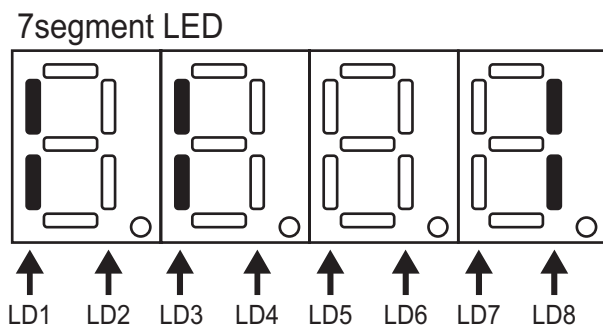

6.6 Display Functions

Select the item to be displayed with SW601 and press SW605 to display the corresponding data in the 7segment LED. The table below shows the display items and the corresponding switch settings.

No.	SW601 [0 : OFF, 1 : ON]								Display item	7segment LED display
	1	2	3	4	5	6	7	8		
0	0	0	0	0	0	0	0	0	Not selected	–
1	0	0	0	0	0	0	0	1	BACnet Communication Service status	0100 : Enable 0101 : Disable 0102 : Disable Initiation
2	0	0	0	0	0	0	1	0	Not used	
3	0	0	0	0	0	0	1	1	Not used	
4	0	0	0	0	0	1	0	0	Not used	
5	0	0	0	0	0	1	0	1	Not used	
6	0	0	0	0	0	1	1	0	Not used	
7	0	0	0	0	0	1	1	1	Not used	
8	0	0	0	0	1	0	0	0	IP Address (LAN1)	*1
9	0	0	0	0	1	0	0	1	IP Address (LAN2)	*1
10	0	0	0	0	1	0	1	0	Not used	
⋮	⋮	⋮	⋮	⋮	⋮	⋮	⋮	⋮		
255	1	1	1	1	1	1	1	1	Not used	

*1 : The IP address of the LAN controller will appear in the decimal notation. Each octet of the four-octet IP addresses will appear at 2-second intervals. The decimal point indicates the octet being displayed.

The IP address 192.168.1.254 will appear as follows in the 7segment LED.

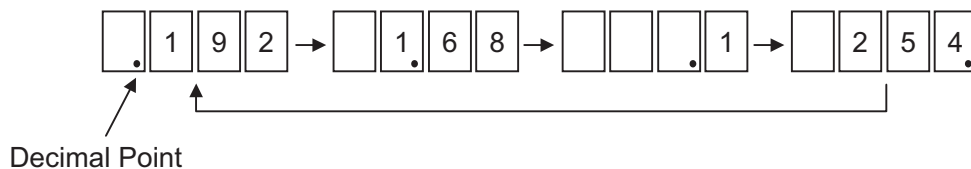

6.7 Operation Functions

Select the type of operation to be executed with SW602, SW606, and SW607, and then press and hold SW605 for two seconds or longer to executed the operation.

The table below shows the operation items and the corresponding switch settings.

No.	SW602 [0 : OFF, 1 : ON]				SW606 and SW607 settings	Operation item
	1	2	3	4		
0	0	0	0	0	–	Not selected
1	0	0	0	1	–	[For maintenance use]
2	0	0	1	0	–	[For maintenance use]
3	0	0	1	1	–	Not used
4	0	1	0	0	–	[For maintenance use]
5	0	1	0	1	–	[For maintenance use]
6	0	1	1	0	–	Not used
7	0	1	1	1	–	Not used
8	1	0	0	0	–	[For maintenance use]
9	1	0	0	1	–	Not used
10	1	0	1	0	–	Not used
11	1	0	1	1	–	Not used
12	1	1	0	0	–	Not used
13	1	1	0	1	–	Not used
14	1	1	1	0	SW606 : F, SW607 : F	Batch operation
15	1	1	1	1	SW606 : F, SW607 : F	Batch stop

CAUTION:

The “For maintenance use” items in the “Operation item” column are used by maintenance providers and should be left as they are.

(1) Batch operation (Sending the "ON" signal to all groups of units)

Set SW602 to "1110," SW606 to "F," and SW607 to "F," and then press and hold SW605 for two seconds or longer to send the "ON" signal to all groups of units.

After the "ON" signal has been sent, "End" will appear in the 7segment LED display.

CAUTION:

When executing a batch operation, the "ON" signal will be sent to all groups of units. The operation status information about each group before the command is executed will not be stored.

To restore the original operation status before the batch operation command was sent, each group needs to be set to ON or OFF individually.

(2) Batch operation (Sending the "OFF" signal to all groups of units)

Set SW602 to "1111," SW606 to "F," and SW607 to "F," and then press and hold SW605 for two seconds or longer to send the "OFF" signal to all groups of units.

After the "OFF" signal has been sent, "End" will appear in the 7segment LED display.

CAUTION:

When executing a batch operation, the "OFF" signal will be sent to all groups of units. The operation status information about each group before the command is executed will not be stored.

To restore the original operation status before the batch operation command was sent, each group needs to be set to ON or OFF individually.

6.8 Error Display

An error code will be displayed in the 7segment LED if an error occurs upon execution of display or operation functions.

No.	Error code	Cause of error
1	Er11	One or more switches on both SW601 and SW602 are set to ON.
2	Er12	One or more of the unavailable switches of SW601 or SW602 are set to ON.
3	Er13	Either SW606 or SW607 is set incorrectly.

6.9 Recommended USB Drives

The following types of USB drives are recommended for use with BAC-HD150.

- Manufacturer : Sandisk Model name : SDCZ6-2048-J65RB Memory size : 2GB
- Manufacturer : Sandisk Model name : SDCZ6-4096RB Memory size : 4GB
- Manufacturer : Kingston Model name : DT400/2GBFE Memory size : 2GB
- Manufacturer : A-DATA Model name : C702 Memory size : 2GB/4GB

There may be some USB drives that are not compatible with BAC-HD150.

7 On-site adjustment steps (When BAC-HD150 is connected to M-NET)

7.1 On-site adjustment flowchart

When BAC-HD150 is connected to M-NET, on-site adjustment is divided into four steps as follows. By following these steps, the cause of trouble can be solved clearly and on-site adjustment can be identified efficiently.

It is recommended to follow the steps below.

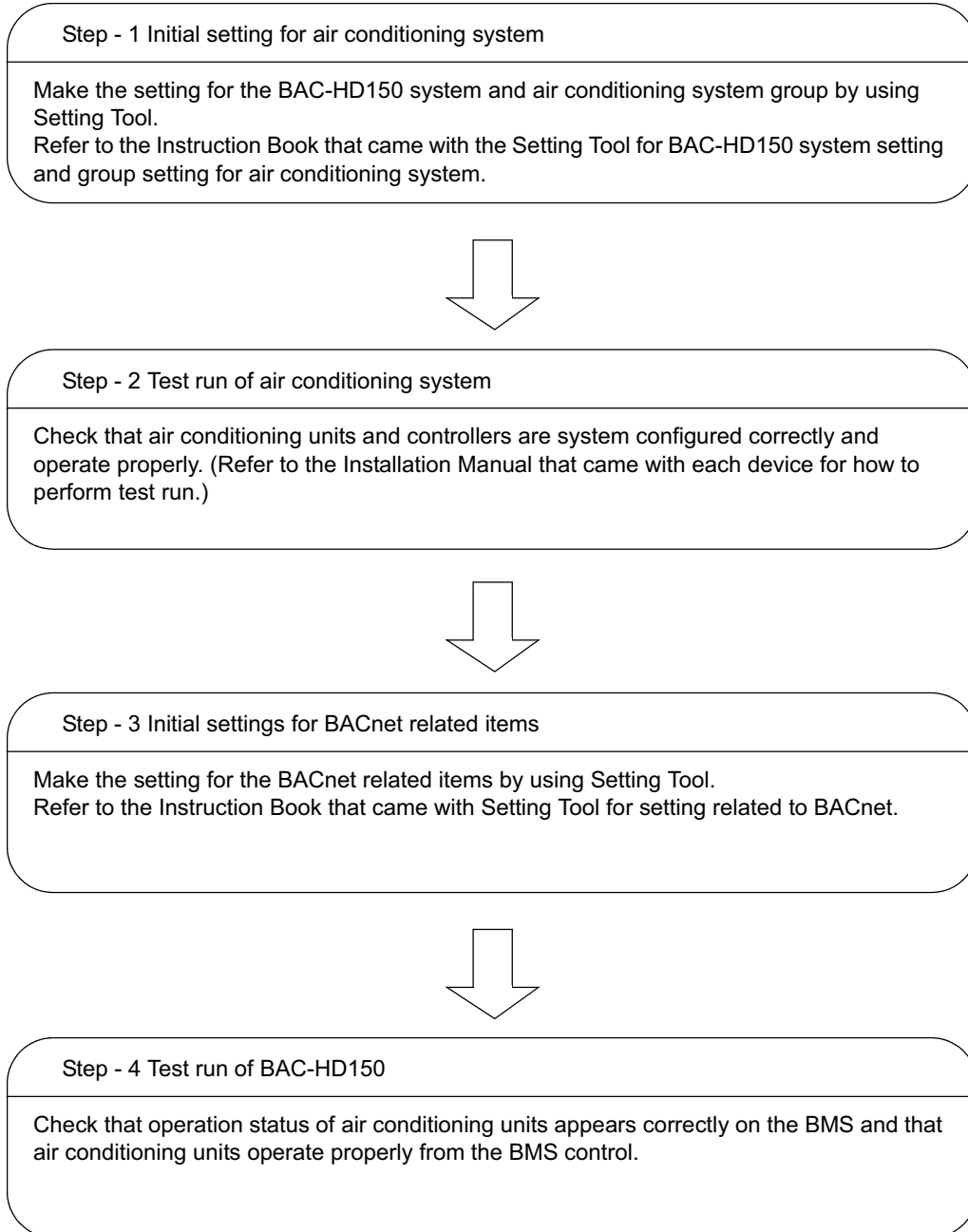

BMS: Building Management System

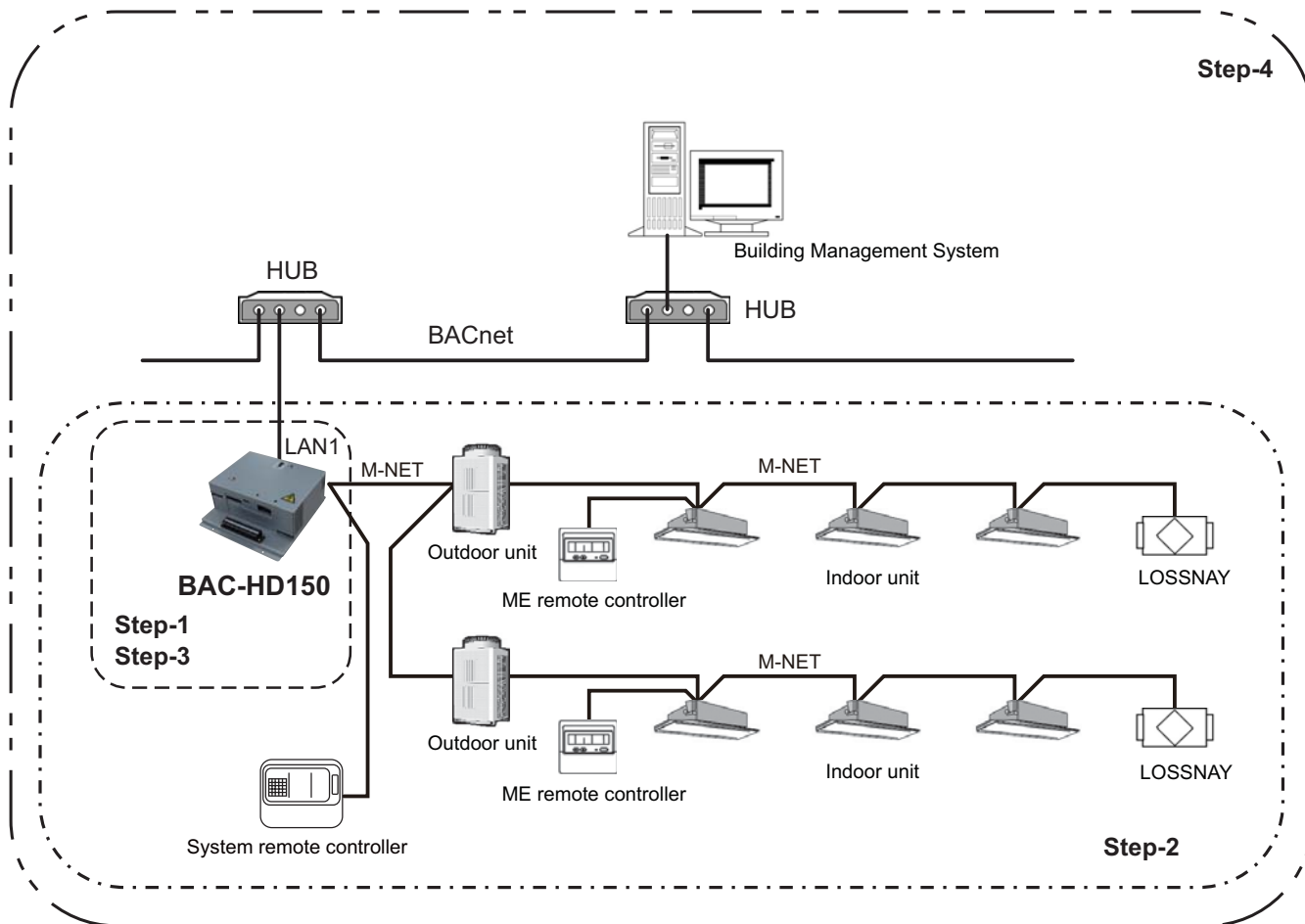

7.2 Preparation for on-site adjustment

Have the following tools and documents ready before performing on-site adjustment and a test run.

Item	Description	Notes
Reference	Air conditioning control system diagram	Group configuration, IP address, Control item, and etc.
	Instruction Book that came with BAC-HD150	(This document)
	Instruction Book that came with Setting Tool	
	BAC-HD150 Installation Manual	
	Relevant air-conditioner and controller's Instructions Books and Installation Manuals	
	Miscellaneous	BACnet device list Documents related to notification items, destinations, and methods.
Tools and parts	Computer	For Setting Tool
	USB memory	For setting data backup
	Installation CD for the Setting Tool	Setup disk
	HUB	For connection to Setting Tool
	Two LAN cables (category 5 or above) (straight cable)	For connection to Setting Tool
	General tools such as a driver	
	Tester	Use to check wiring and voltage.
	Miscellaneous	

7.3 Step - 1 Initial setting for air conditioning system

Make the initial settings for air conditioning system using Setting Tool.

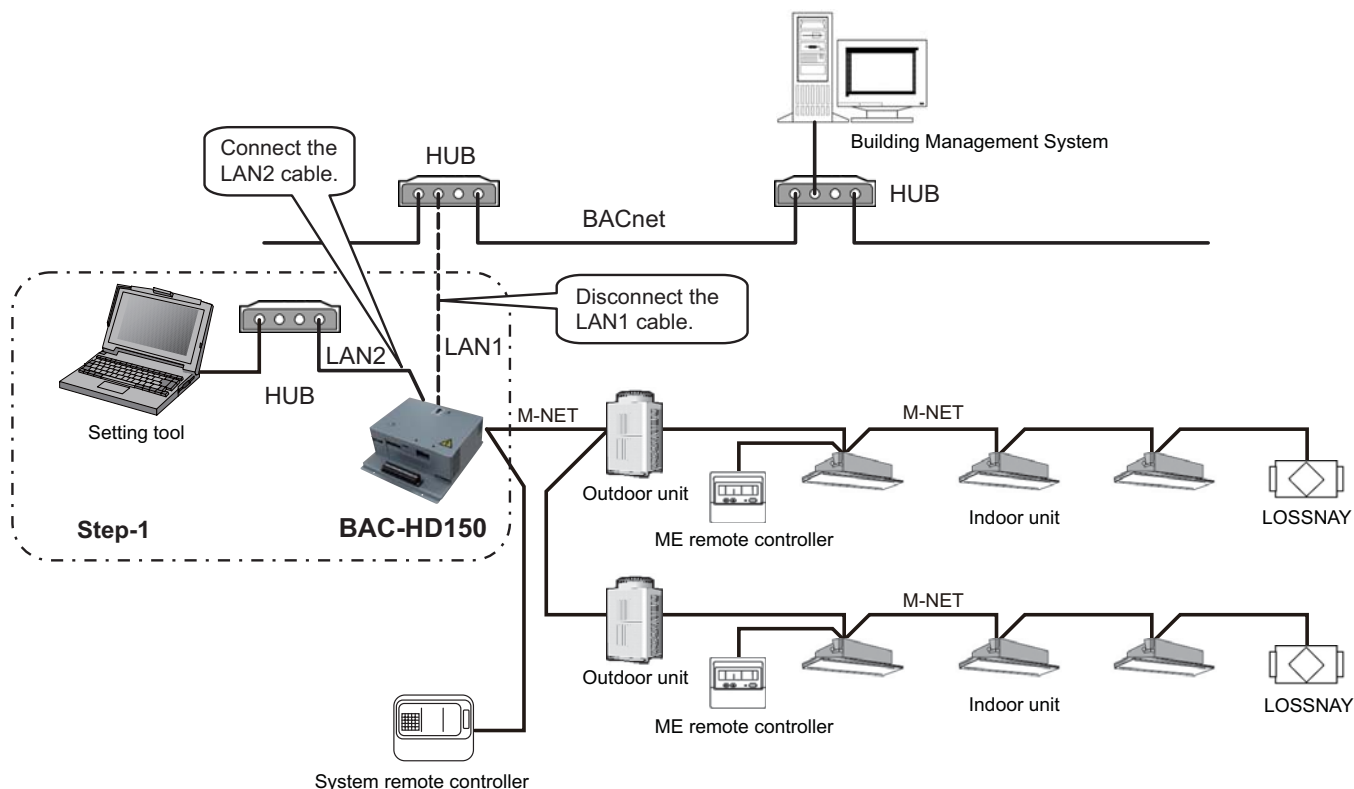

- (1) Installing the Setting Tool software
Install the Setting Tool program on a PC, and set the IP address. (Refer to the Instruction Book that came with Setting Tool for installation and setting method.)
- (2) Connecting the Setting Tool
Disconnect the LAN1 cable connected to BACnet of BAC-HD150.
Use additional HUB to connect BAC-HD150 and Setting Tool.
Connect the LAN2 cable that is connected to BACnet to the additional HUB.
- (3) Data setting
Make the settings for the air conditioning system related items and IP address of BAC-HD150 by using Setting Tool.
The following table shows setting items. (Refer to the Instruction Book that came with Setting Tool for setting method.)

No.	Main tab	Sub tab	Setting item
1	System Settings	Basic System	All setting items
2		M-NET	All setting items
3		Expansion Controller	No settings required
4	Group Settings	Group	All setting items
5		LOSSNAY	All setting items

CAUTION
If IP address of BAC-HD150 overlaps any of the addresses that are assigned to other devices, communications cannot be performed properly via BAC-HD150 or other devices. Check the address before setting.

MEMO :
When settings are changed by using Setting Tool after the initial settings have been completed, it is not necessary to disconnect the LAN1 cable from BACnet.

7.4 Step - 2 Test run of air conditioning system

Perform test run only on air conditioning system.

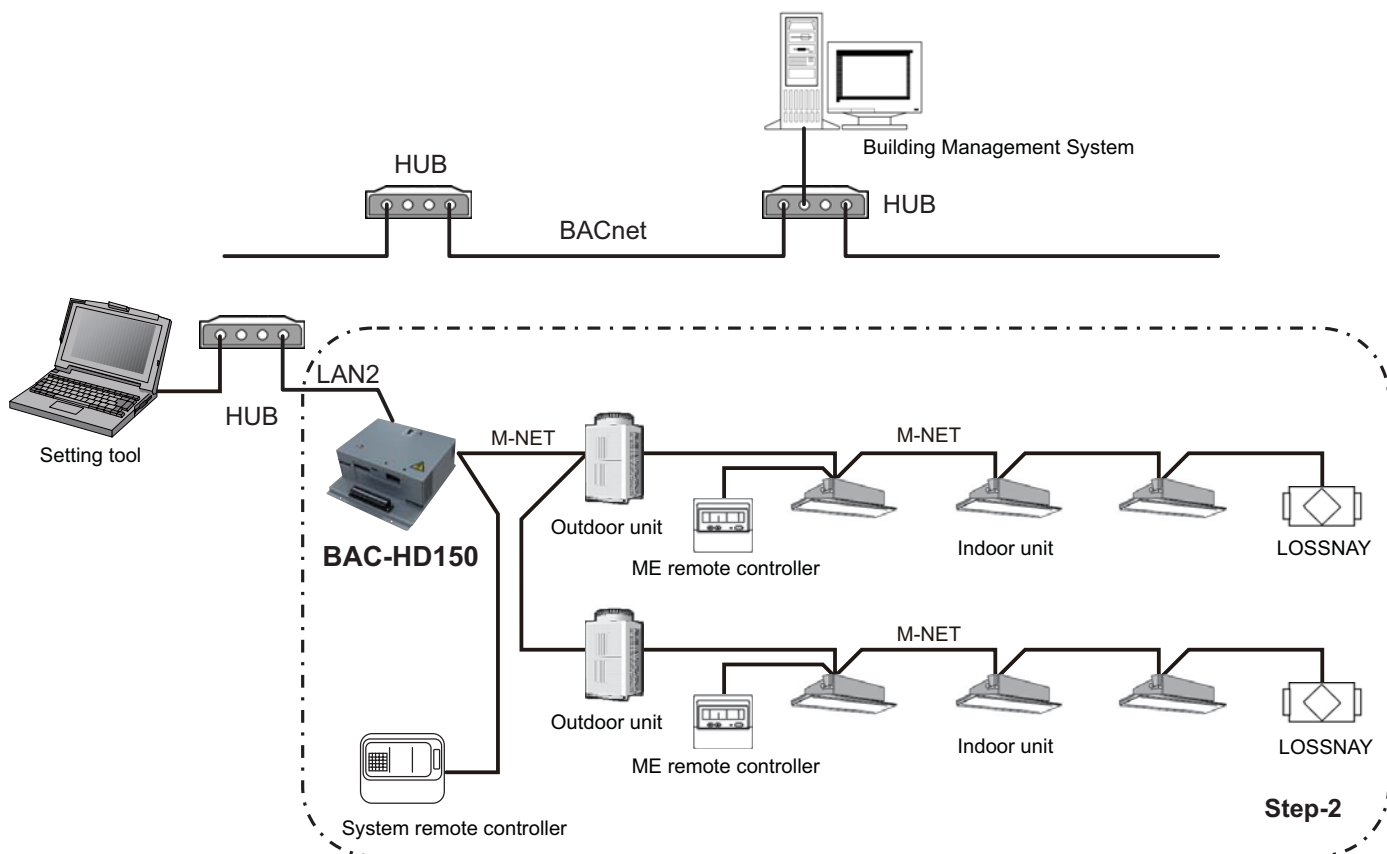

- (1) Checking items before test run
Check that test run of air conditioning units is completed.
- (2) Turning on the power of all the air conditioning units and system controllers
Turn on the power of all the air conditioning units and system controllers (ex. System remote controller).
- (3) Restarting the BAC-HD150
Restarting the BAC-HD150, then it becomes [Online mode].
The setting data made in Step - 1 such as air conditioning system group is automatically sent from BAC-HD150 to air conditioning system.
(It may take about 5 minutes for the setting.)
- (4) Test run using system controller or remote controller
Perform test run using system controller or remote controller to check operation status of each unit.

* Refer to the Installation Manual that came with air conditioning unit and system controller for how to perform test run.

7.5 Step - 3 Initial settings for the BAC-HD150 related items

Make the initial settings for BACnet using Setting Tool.

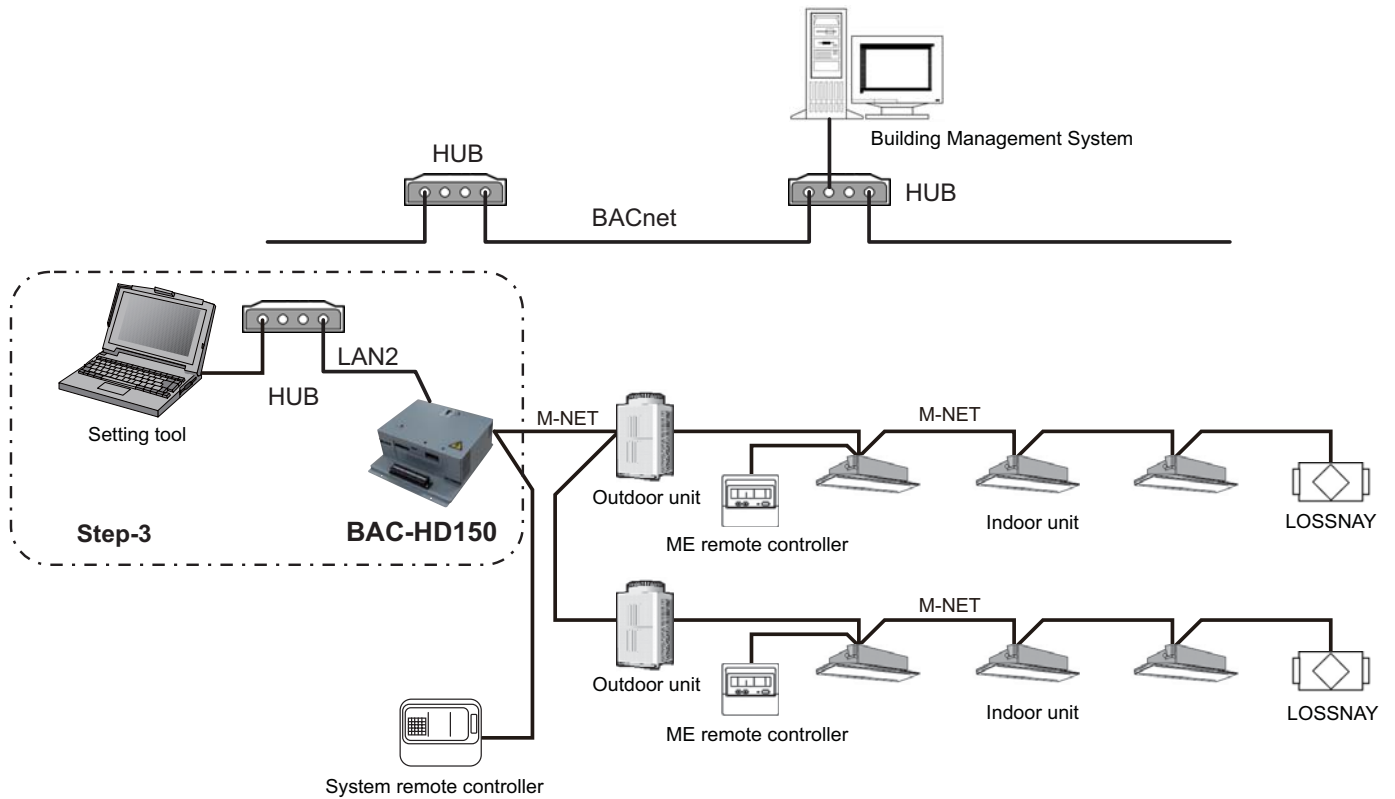

(1) Data setting

Make the settings for BACnet using Setting Tool.

The following table shows setting items. (Refer to the Instruction Book that came with Setting Tool for setting method.)

No.	Main tab	Sub tab	Setting item
1	BACnet Settings	BACnet	All setting items
2		Network and Device	All setting items
3		COV Notification	All setting items
4		Event Notification	All setting items
5		Object	All setting items
6		Other	All setting items

7.6 Step - 4 Test run of BAC-HD150

Connect BMS and perform test run of air conditioning system.

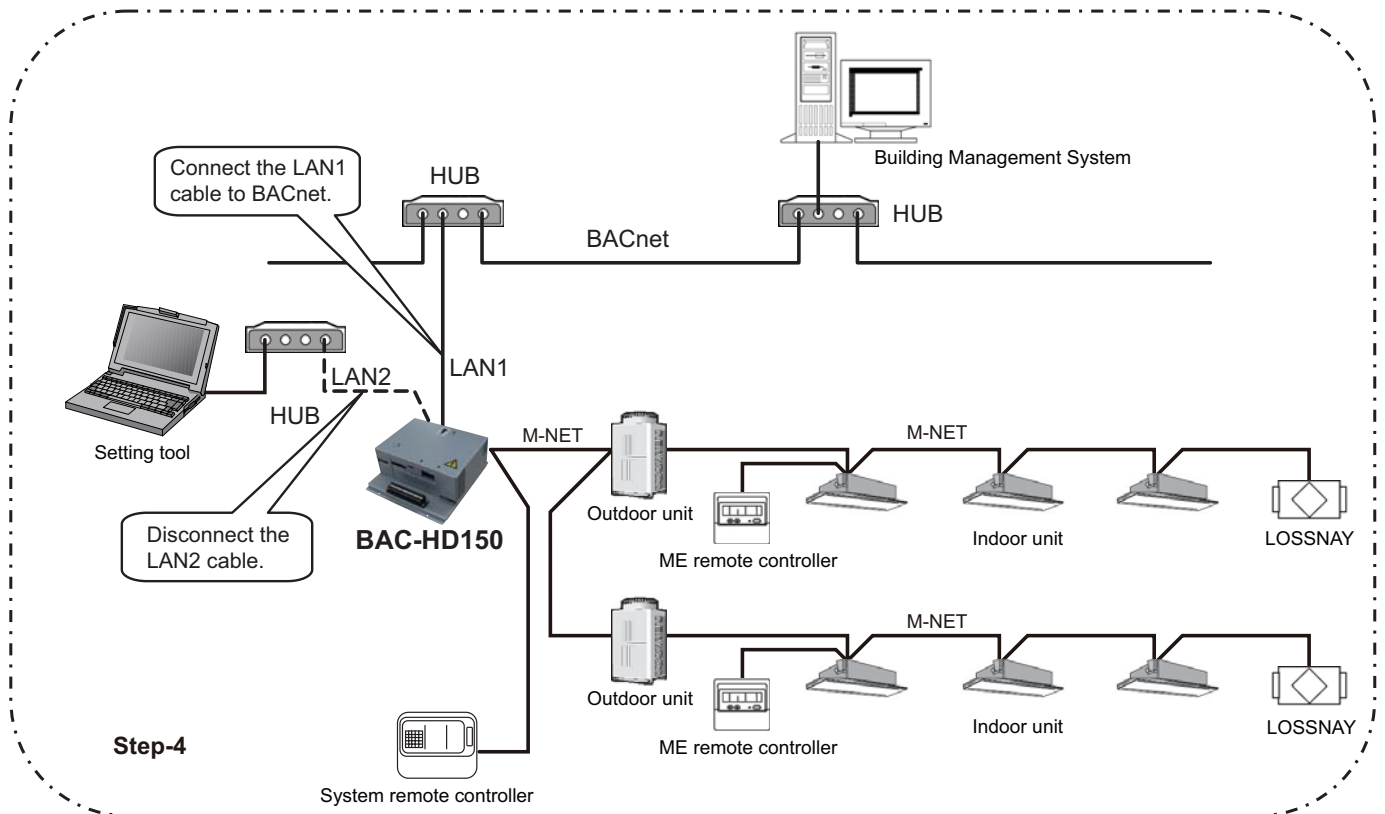

- (1) Cutting the connection of Setting Tool
Disconnect the LAN2 cable that is connected to BAC-HD150 from the Setting Tool.
- (2) BACnet connection
Connect the LAN1 cable that is connected to BAC-HD150 to BACnet.
- (3) Restarting the BAC-HD150
Restart BAC-HD150, then it becomes [Online mode].
- (4) Test run items and method
Refer to "Appendix On-site adjustment sheet for BAC-HD150 (proposal)" for the test run items and method.

8 On-site adjustment steps (When BAC-HD150 is connected to PAC-YG50ECA)

8.1 On-site adjustment flowchart

When BAC-HD150 is connected to PAC-YG50ECA, on-site adjustment is divided into two steps as follows.
Before following the steps below, set the M-NET address, group, and interlocked operation with LOSSNAY for PAC-YG50ECA by using AG-150A, and complete a test run for the air conditioning units.
By following these steps, the cause of trouble can be solved clearly and on-site adjustment can be identified efficiently.

It is recommended to follow the steps below.

Step - 1 Initial settings for the BAC-HD150 system and BACnet related items

Make the setting for the BAC-HD150 system and BACnet related items by using Setting Tool.
(Refer to the Instruction Book that came with Setting Tool for BAC-HD150 system setting and setting related to BACnet.)

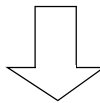

Step - 2 Test run of BAC-HD150

Check that operation status of conditioning units appears correctly on the BMS and that air conditioning units operate properly from the BMS control.

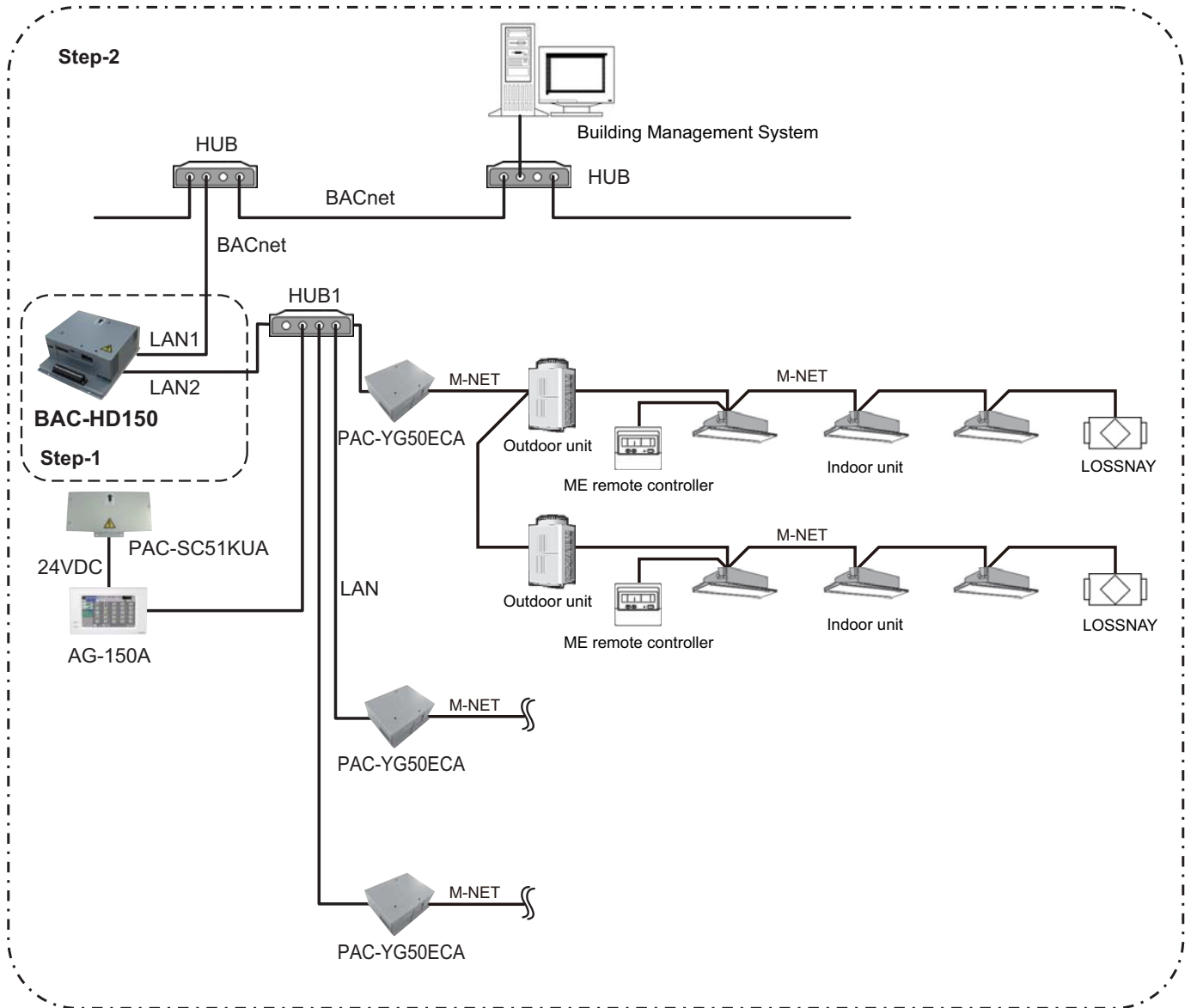

8.2 Preparation for on-site adjustment (Same as section 7.2 “Preparation for on-site adjustment”)
 Have the following tools and documents ready before performing on-site adjustment and a test run.

Item	Description	Notes
Reference	Air conditioning control system diagram	Group configuration, IP address, Control item, and etc.
	Instruction Book that came with BAC-HD150	(This document)
	Instruction Book that came with Setting Tool	
	BAC-HD150 Installation Manual	
	Relevant air-conditioner and controller's Instructions Books and Installation Manuals	
	Miscellaneous	BACnet device list Documents related to notification items, destinations, and methods.
Tools and parts	Computer	For Setting Tool
	USB memory	For setting data backup
	Installation CD for the Setting Tool	Setup disk
	HUB	For connection to Setting Tool
	Two LAN cables (category 5 or above) (straight cable)	For connection to Setting Tool
	General tools such as a driver	
	Tester	Use to check wiring and voltage.
	Miscellaneous	

8.3 Step-1 Initial setting for air conditioning system

Make the setting for the BAC-HD150 system and BACnet related items by using Setting Tool.

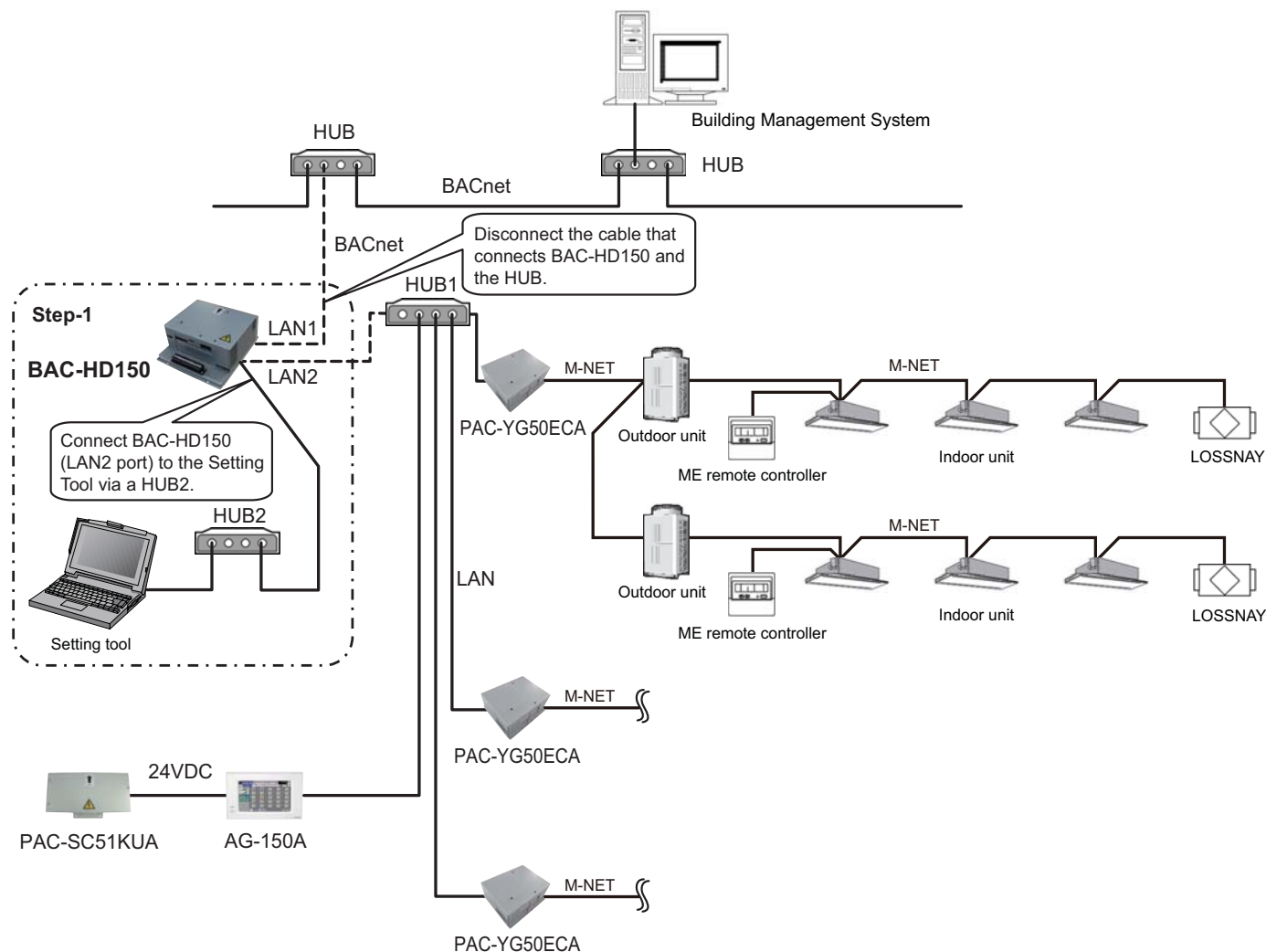

- (1) Installing the Setting Tool software
Install the Setting Tool program on a PC, and set the IP address. (Refer to the Instruction Book that came with Setting Tool for installation and setting method.)
- (2) Disconnecting the BACnet
Disconnect the LAN1 cable that is connected to BAC-HD150 from BACnet.
- (3) Connecting the Setting Tool
Use additional HUB2 to connect BAC-HD150 and Setting Tool.
Disconnect the cable that is connected to LAN2 port of BAC-HD150 from HUB1, and connect it to the additional HUB2.

(4) Data setting

Make the setting for the BAC-HD150 system and BACnet related items by using Setting Tool.

The following table shows setting items. (Refer to the Instruction Book that came with Setting Tool for setting method.)

No.	Main tab	Sub tab	Setting item
1	System Settings	Basic System	All setting items
2		M-NET	No settings required
3		Expansion Controller	Access Point Settings
4	Group Settings	Group	No settings required
5		LOSSNAY	No settings required
6	BACnet Settings	BACnet	All setting items
7		Network and Device	All setting items
8		COV Notification	All setting items
9		Event Notification	All setting items
10		Object	All setting items
11		Other	All setting items

When BAC-HD150 is connected to PAC-YG50ECA, the settings of the M-NET address, group, and interlocked operation with LOSSNAY are made by using AG-150A. It is not necessary to make these settings on BAC-HD150.

CAUTION

If IP address of BAC-HD150 overlaps any of the addresses that are assigned to other devices, communications cannot be performed properly via BAC-HD150 or other devices. Check the address before setting.

MEMO :

When settings are changed by using Setting Tool after the initial settings have been completed, it is not necessary to disconnect the LAN1 cable from BACnet and the LAN2 cable from HUB1.

8.4 Step-2 Test run of BAC-HD150

Connect BMS and perform test run of air conditioning system.

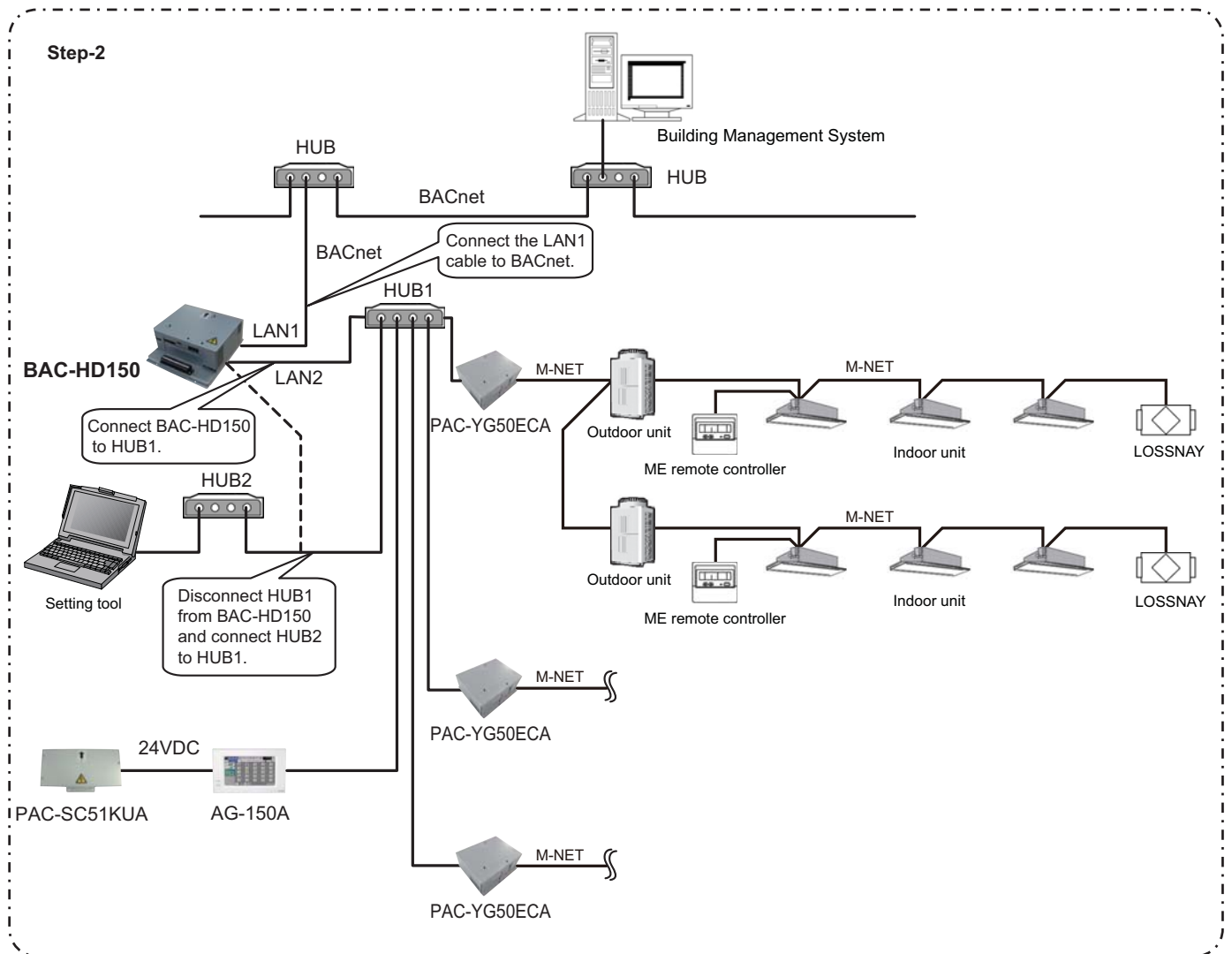

- (1) Checking items before test run
Check that test run of air conditioning units is completed.
- (2) Turning on the power of all the air conditioning units and system controllers
Turn on the power of all the air conditioning units and system controllers (ex. PAC-YG50ECA and AG-150A (PAC-SC51KUA)).
- (3) Checking for IP address overlaps between LAN 2 port of BAC-HD150 and other devices
Disconnect HUB 2 from BAC-HD150 (LAN 2 port), and connect HUB 2 to HUB 1. To check for address overlap, send a PING of an IP address that is assigned to LAN 2 port of BAC-HD150.
- (4) Confirming the PAC-YG50ECA settings and restarting BAC-HD150
Connect BAC-HD150 and HUB 1, using LAN 2 port of BAC-HD150. From the Setting Tool, execute the "Get Settings" command to acquire the settings information about PAC-YG50ECA, and check that the Expansion Controller Settings match the settings that were made from AG-150A. Refer to section 8.2.3.1 "Acquiring the settings information for the Expansion Controller settings" in the BAC-HD150 Setting Tool Instruction Book for how to acquire the settings information of PAC-YG50ECA. Restart BAC-HD150, then it becomes [Online mode].
- (5) Disconnecting the Setting Tool and connecting BAC-HD150 to HUB on the BACnet
Disconnect the cable that connects HUB 1 and HUB 2. Connect BAC-HD150 to HUB on the BACnet, using LAN 1 port of BAC-HD150.
- (6) Test run items and method
Refer to "Appendix On-site adjustment sheet for BAC-HD150 (proposal)" for the test run items and method.

Appendix On-site adjustment sheet for BAC-HD150 (proposal)

Check these items to use the system.

Group No. []

Control item	Object	Status	Steps	Result
On Off Setup	BO_xxxx01	INACTIVE: Stop ACTIVE: Run	<ul style="list-style-type: none"> Turn ON/OFF the specific group from BMS(*1). After doing so, check that the operation status of the group renews the condition using system controller or remote controller.	
On Off State	BI_xxxx02	INACTIVE: Stop ACTIVE: Run	<ul style="list-style-type: none"> Turn ON/OFF the specific group using system controller or remote controller. After doing so, check that the operation status of the group renews the condition on BMS .	
Alarm Signal	BI_xxxx03	INACTIVE: Normal ACTIVE: Error	<ul style="list-style-type: none"> Make an error on an air conditioning units of the specific group. After doing so, check that the warning signal of the group turns to (ACTIVE) on BMS. (*2) <ul style="list-style-type: none"> Recover the error of the air conditioning units of the specific group. After doing so, check that the warning signal of the group turns to (INACTIVE) on BMS.	
Error Code	MI_xxxx04	01 : Normal 02 : Other errors 03 : Refrigeration fault 04 : Water error 05 : Air error 06 : Electronic error 07 : Sensor fault 08 : Communication error 09 : System error	<ul style="list-style-type: none"> Disconnect M-NET transmission line that is connected to BAC-HD150. After doing so, check that the error code of all groups turns to Communication error (08) on BMS. (*3) <ul style="list-style-type: none"> Connect M-NET transmission line to BAC-HD150. After doing so, check that the error code of all groups turns to Normal (01) on BMS. (Do not perform this check when other errors occur.)	
Operational Mode Setup	MO_xxxx05	01 : Cooling 02 : Heating 03 : Fan 04 : Auto 05 : Dry (*4)	<ul style="list-style-type: none"> Change operation mode of the specific group from BMS. After doing so, check that the operation mode of the group renews the mode using system controller or remote controller.	
Operational Mode State	MI_xxxx06	01 : Cooling 02 : Heating 03 : Fan 05 : Dry (*4)	<ul style="list-style-type: none"> Change operation mode of the specific group using system controller or remote controller. After doing so, check that the operation mode of the group renews the mode on BMS.	
Fan Speed Setup	MO_xxxx07	01 : Low 02 : High 03 : Mid 2 (*5) 05 : Mid 1 (*5)	<ul style="list-style-type: none"> Change fan speed of the specific group from BMS. After doing so, check that the fan speed of the group renews the speed using system controller or remote controller.	
Fan Speed State	MI_xxxx08	01 : Low 02 : High 03 : Mid 2 (*5) 04 : Mid 1 (*5)	<ul style="list-style-type: none"> Change fan speed of the specific group using system controller or remote controller. After doing so, check that the fan speed of the group renews the speed on BMS.	
Room temp [Water Temp] (*6)	AI_xxxx09	°C	<ul style="list-style-type: none"> Change intake air temperature and check if the display of BMS and system controller/remote controller are the same. 	
Set Temp [Set Water Temp] (*6)	AV_xxxx10	°C	<ul style="list-style-type: none"> Make a setting of set room temperature of the specific group from BMS. After doing so, check that the set room temperature of the group renews the temperature using system controller or remote controller. <ul style="list-style-type: none"> Change the set room temperature of the specific group using system controller or remote controller. After doing so, check that the set room temperature of the group renews the temperature on BMS.	
Filter Sign [Circulating Water Exchange Sign] (*6)	BI_xxxx11	INACTIVE : OFF ACTIVE : ON	<ul style="list-style-type: none"> Perform something to turn on the filter sign. (*2) After doing so, check that the filter sign of the group turns to ON(ACTIVE) on BMS.	
Filter Sign Reset [Circulating Water Exchange Sign Reset] (*6)	BV_xxxx12	INACTIVE : RESET ACTIVE : Void	<ul style="list-style-type: none"> Reset the filter sign of the group that detects filter sign [ON(ACTIVE)] from BMS. (*2) After doing so, check that the filter sign of the group turns to OFF(INACTIVE) on BMS.	

Control item	Object	Status	Steps	Result
Prohibition On Off	BV_xxxx13	INACTIVE : Permit ACTIVE : Prohibit	<ul style="list-style-type: none"> Prohibit the remote controller (ON/OFF) of the specific group from BMS. After doing so, check that the remote controller (ON/OFF) of the group turns to (ACTIVE) via the remote controller. <ul style="list-style-type: none"> Permit the remote controller (ON/OFF) of the specific group from BMS. After doing so, check that the remote controller (ON/OFF) of the group turns to (INACTIVE) via the remote controller.	
Prohibition Mode	BV_xxxx14	INACTIVE : Permit ACTIVE : Prohibit	<ul style="list-style-type: none"> Operation/checking object is the same as the steps of remote controller (operation mode), but the checking method is the same as the steps of remote controller (ON/OFF). 	
Prohibition Filter Sign Reset [Prohibition Circulating Water Exchange Sign Reset] (*6)	BV_xxxx15	INACTIVE : Permit ACTIVE : Prohibit	<ul style="list-style-type: none"> Operation/checking object is the same as the steps of remote controller (filter sign reset), but the checking method is the same as the steps of remote controller (ON/OFF). 	
Prohibition Set Temperature	BV_xxxx16	INACTIVE : Permit ACTIVE : Prohibit	<ul style="list-style-type: none"> Operation/checking object is the same as the steps of remote controller (set temperature), but the checking method is the same as the steps of remote controller (ON/OFF). 	
M-NET Communication State	BI_xxxx20	INACTIVE: Normal ACTIVE: Error	<ul style="list-style-type: none"> Disconnect M-NET transmission line which is connected to BAC-HD150 or PAC-YG50ECA. After doing so, check that the M-NET communication status of all groups turns to Error (ACTIVE) on BMS. (*3) <ul style="list-style-type: none"> Connect M-NET transmission line to BAC-HD150 or PAC-YG50ECA. After doing so, check that the M-NET communication status of all groups turns to Normal (INACTIVE) on BMS.	
System Forced Off	BV_xxxx21 BV_999921	INACTIVE: Reset ACTIVE: Execute	<ul style="list-style-type: none"> Perform a forced stop of the system of the specific group from BMS. After doing so, check that the air conditioner stops on BMS.	
Air Direction Setup	MO_xxxx22	01 : Horizontal 02 : Downblow 60% 03 : Downblow 80% 04 : Downblow 100% 05 : Swing	<ul style="list-style-type: none"> Change the air direction of the specific group from BMS. After doing so, check that the air direction of the group renews the direction using system controller or remote controller.	
Air Direction State	MI_xxxx23	01 : Horizontal 02 : Downblow 60% 03 : Downblow 80% 04 : Downblow 100% 05 : Swing	<ul style="list-style-type: none"> Change the air direction of the specific group using system controller or remote controller. After doing so, check that the air direction of the group renews the direction on BMS.	
Ventilation Mode Setup	MO_xxxx35	01 : Heat exchange 02 : Bypass 03 : Auto	<ul style="list-style-type: none"> Change the LOSSNAY ventilation mode of the specific group from BMS. After doing so, check that the LOSSNAY ventilation mode of the group renews the mode using system controller or remote controller.	
Ventilation Mode State	MI_xxxx36	01 : Heat exchange 02 : Bypass 03 : Auto	<ul style="list-style-type: none"> Change the LOSSNAY ventilation mode of the specific group using system controller or remote controller. After doing so, check that the LOSSNAY ventilation mode of the group renews the mode on BMS.	
Air To Water Mode Setup	MO_xxxx37	01 : Heating 02 : Heating ECO 03 : Hot Water 04 : Anti-Freeze 05 : Cooling	<ul style="list-style-type: none"> Change the Air To Water mode of the specific group from BMS. After doing so, check that the Air To Water mode of the group renews the mode using system controller or remote controller.	
Air To Water Mode State	MO_xxxx38	01 : Heating 02 : Heating ECO 03 : Hot Water 04 : Anti-Freeze 05 : Cooling	<ul style="list-style-type: none"> Change the Air To Water mode of the specific group using system controller or remote controller. After doing so, check that the Air To Water mode of the group renews the mode on BMS.	
Expansion Controller Communication State	BI_xx9981	INACTIVE : Normal ACTIVE : Error	<ul style="list-style-type: none"> Disconnect the cable that is connected to the BAC-HD150 (LAN 2 port). Confirm that the Expansion Controller communication status changes to "Error (ACTIVE)" on the BMS. Reconnect the cable as it was, and confirm that the Expansion Controller communication status changes to "Normal (INACTIVE)" on the BMS. 	

*1: BMS = Building Management System

*2: Consult a Mitsubishi personnel for the confirmation method.

*3: It can take up to five minutes for an error to be detected.

*4: "Dry" can be used only when "use" is selected for the "Dry" setting ("Dry" is not used for a default.)

*5: "Mid 1/Mid 2" can be used only when "use" is selected for the "Mid 1/Mid 2" setting. ("Mid 1/Mid 2" is not used for a default.)

*6: Inside the brackets indicates control item for BU or AU group. (Refer to section 1.2 Restrictions/Cautions.)

NOTE:

This equipment has been tested and found to comply with the limits for a Class B digital device, pursuant to Part 15 of the FCC Rules. These limits are designed to provide reasonable protection against harmful interference in a residential installation. This equipment generates, uses and can radiate radio frequency energy and, if not installed and used in accordance with the instructions, may cause harmful interference to radio communications.

However, there is no guarantee that interference will not occur in a particular installation.

If this equipment does cause harmful interference to radio or television reception, which can be determined by turning the equipment off and on, the user is encouraged to try to correct the interference by one or more of the following measures:

- Reorient or relocate the receiving antenna.
- Increase the separation between the equipment and receiver.
- Connect the equipment into an outlet on a circuit different from that to which the receiver is connected.
- Consult the dealer or an experienced radio / TV technician for help.

This product is designed and intended for use in the residential,
commercial and light-industrial environment.

The product at hand is
based on the following
EU regulations:

- Low Voltage Directive 2006/95/EC
- Electromagnetic Compatibility Directive,
2004/108/EC

Please be sure to put the contact address/telephone number on
this manual before handing it to the customer.

 **MITSUBISHI ELECTRIC CORPORATION**

HEAD OFFICE: TOKYO BLDG., 2-7-3, MARUNOUCHI, CHIYODA-KU, TOKYO 100-8310, JAPAN

Authorized representative in EU: MITSUBISHI ELECTRIC EUROPE B.V.

HARMAN HOUSE, 1 GEORGE STREET, UXBRIDGE, MIDDLESEX UB8 1QQ, U.K.

WT05542X03
Printed in Japan
Recycled Paper